

REVISION HISTORY			
REV.	DESCRIPTION	DATE	DRAWN BY
1	ORIGINAL PRINT	3/9/2023	P. YEUNG

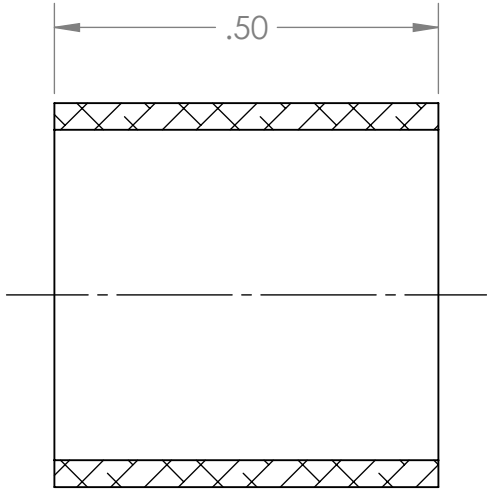

SECTION A-A

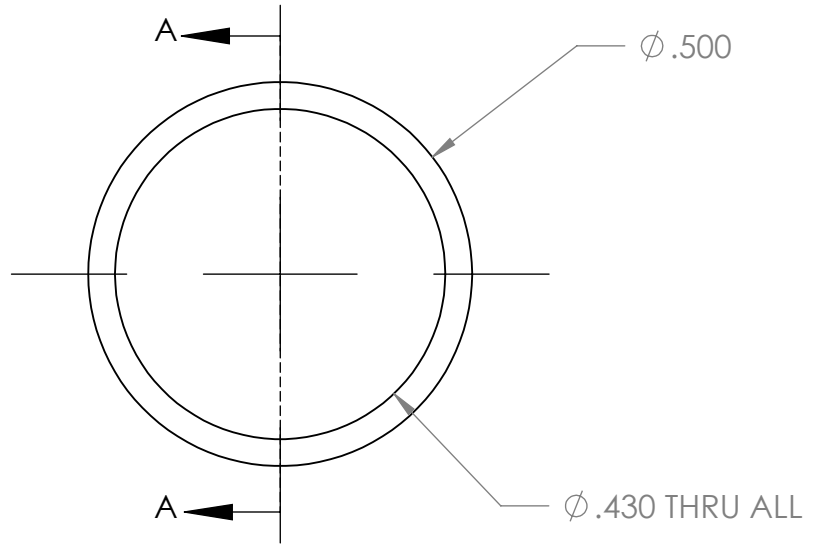

*** SEE CAD FOR ADDITIONAL TOOLPATH INFO***

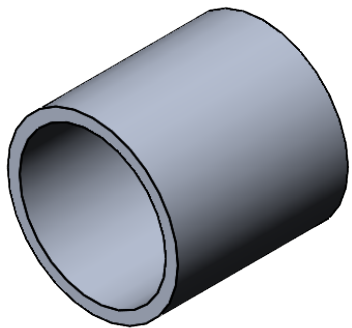

UNLESS OTHERWISE SPECIFIED:		COMMENTS:																
DIMENSIONS ARE IN INCHES		DUAL DIMENSIONS ARE IN MILLIMETERS.																
TOLERANCES:		BREAK ALL SHARP EDGES.		TITLE: 0.430 ID 0.500 OD 0.50 LONG ALUMINUM SPACER														
FRACTIONAL	±1/16	<table border="1"> <tr> <td>CHECKED</td> <td>NAME</td> <td>DATE</td> </tr> <tr> <td>ENG APPR.</td> <td>NM</td> <td>3/9/23</td> </tr> <tr> <td>MFG APPR.</td> <td></td> <td></td> </tr> <tr> <td>Q.A.</td> <td></td> <td></td> </tr> </table>					CHECKED	NAME	DATE	ENG APPR.	NM	3/9/23	MFG APPR.			Q.A.		
CHECKED	NAME						DATE											
ENG APPR.	NM						3/9/23											
MFG APPR.																		
Q.A.																		
ANGULAR: MACH	±1°																	
ANGULAR: BEND	±5°																	
ONE PLACE DECIMAL	±0.1	MATERIAL		SIZE	DWG. NO.	REV												
TWO PLACE DECIMAL	±0.01	AL 6061-T6		A	am-1699	1												
THREE PLACE DECIMAL	±0.005	FINISH		SCALE: 4:1 SHEET 1 OF 1														
FOUR PLACE DECIMAL	±0.0005	DEBURRED																
DO NOT SCALE DRAWING																		