

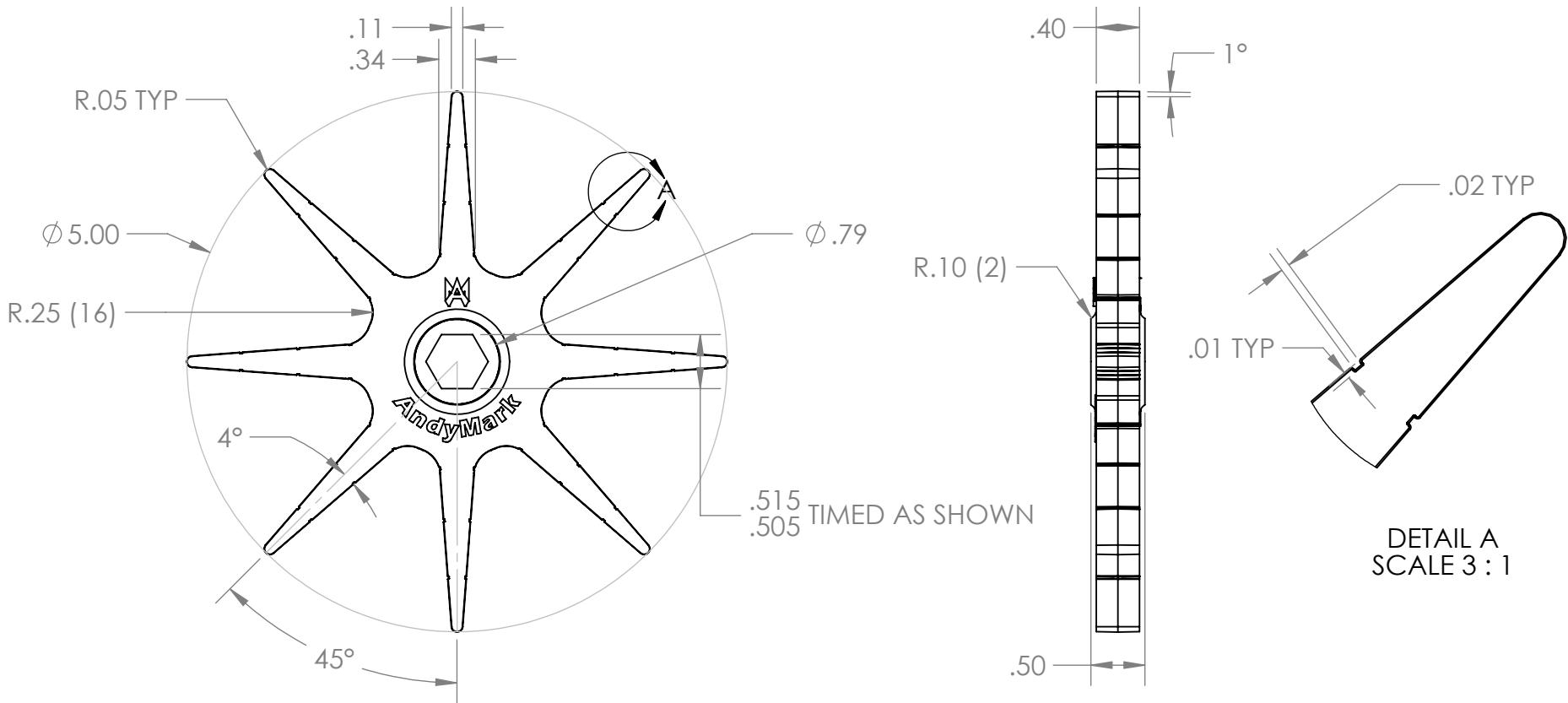

REVISION HISTORY			
REV.	DESCRIPTION	DATE	DRAWN BY
1	ORIGINAL PRINT	9/18/2023	E. SCIME

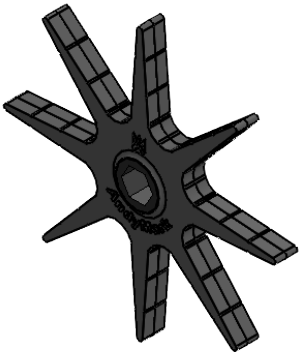

*** SEE CAD FOR ADDITIONAL TOOLPATH INFO***



UNLESS OTHERWISE SPECIFIED:		COMMENTS:				
DIMENSIONS ARE IN INCHES		DUAL DIMENSIONS ARE IN MILLIMETERS.				
TOLERANCES:		BREAK ALL SHARP EDGES.		TITLE:		
FRACTIONAL	±1/16			5IN 500IN HEX BORE		
ANGULAR: MACH	±1°			COMPLIANT STAR		
ANGULAR: BEND	±5°					
ONE PLACE DECIMAL	±0.1					
TWO PLACE DECIMAL	±0.01	MATERIAL PC CORE		CHECKED	NAME	DATE
THREE PLACE DECIMAL	±0.005	TPU OVERMOLD		ENG APPR.	NM	10/30/23
FOUR PLACE DECIMAL	±0.0005	FINISH		MFG APPR.		
DO NOT SCALE DRAWING		DEBURRED		Q.A.		
				SIZE	DWG. NO.	REV
				A	am-5123	1
				SCALE: 1:1.5		SHEET 1 OF 1

5

4

3

2

1