









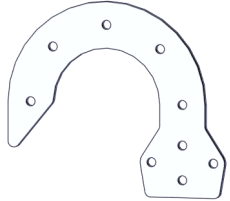

Assembly Guide

Climber in a Box

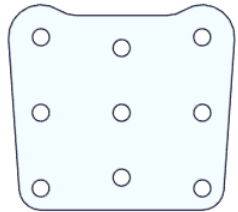





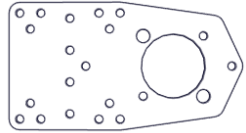

Creates 1-Stage am-4667 or 2-Stage am-4668

Parts Used:

Component	Product Number	Qty	Product Photo
1 x 1 x .063 30IN Square Tube	am-4203-30	1	
1.5 x 1.5 x 0.063 30IN Square Tube	am-4669-30	1	
2.0 x 2.0 x 0.063 30IN Square Tube	am-4670-30	1	
Hook Assembly (am-4660)			
Climber In A Box Hook Plate	am-4654	2	
1IN 3/8 OD .192ID Aluminum Spacer	am-3876	7	
10-32 x 1.500 SHCS	am-1014	9	
10-32 Nylock Jam Nut	am-1063	9	
1.5" to 1" Bearing Assembly (am-4661)			
1.5" Bearing Plate	am-4644	2	
1.5" 3/8 OD Round Spacer	am-1599	4	
Spacer, 1/2 OD x .375 ID x .688 IN Long Plastic Spacer	am-1611	2	
5/16 OD 1.5" long #10 Aluminum Spacer	am-1503	2	

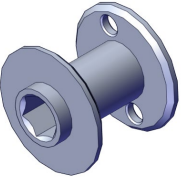
Climber In A Box Inside Slider Block	am-4629	2	
Climber In A Box 1x1 Clamp Slider Block	am-4630	2	
5/16" OD .875" Long #10 AL Standoff	am-1613	1	
Constant force spring	am-4657	2	
5/16" Hardened Steel Washer	am-1009	8	
608 Bearing	am-4456	4	
10-32 Nylock Jam Nut	am-1063	10	
10-32 Jam Nut	am-1612	6	
10-32 x 2000 SHCS	am-1049	6	
10-32 x 375 BHCS with Patch	am-1588	8	
#10 Washer	am-1026	6	
10-32 x 500 FHCS with Patch	am-1505	4	
2.0" to 1.5" Bearing Assembly (am-4662)			
2.0" Bearing Plate	am-4645	2	
2.0" 3/8 OD Round Spacer	am-1600	4	

Spacer, .47 OD x .33 ID x 1.18 IN Long Plastic Spacer	am-1610	2	
5/16 OD 2.0" long #10 Aluminum Spacer	am-1582	2	
Climber In A Box Inside Slider Block	am-4629	2	
Climber In A Box 1.5x1.5 Clamp Slider Block	am-4631	2	
Constant Force Spring	am-4657	2	
5/16" Hardened Steel Washer	am-1009	8	
608 Bearing	am-4456	4	
10-32 Nylock Jam Nut	am-1063	12	
10-32 Jam Nut	am-1612	6	
10-32 x 2500 SHCS	am-1024	6	
10-32 x 375 BHCS with Patch	am-1588	8	
#10 Washer	am-1026	6	
10-32 x 500 FHCS with Patch	am-1505	4	

1.5" OR 2.0" Winch Assembly (am-4663)			
Climber In A Box Winch Plate	am-4646	2	
1.125IN Bearing Plate	am-3722	1	
1.5" 3/8 OD Round Spacer OR 2.0" 3/8 OD Round Spacer	am-1599/am-1600	5	
10' Silver Dyneema Rope	am-4559	1	
10-32 x 2000 SHCS OR 10-32 x 2.500 SHCS	am-1049	6	
10-32 Nylock Jam Nut	am-1063	12	
Climber In A Box Winch Spool	am-4647_1500	1	
500 Hex HD Bearing	am-2986	1	
10-32 x 500 BHCS	am-1512	8	
1.313 long .192 ID . 375 OD AL Spacer	am-1601	1	

Assemble Hook

Hook will be installed on the 1.0" box tube. The hook is also used as drill guides for the box tubes.

Step 1: Align Hook Plates (am-4654) and 5 spacers (am-3976) as shown. The hook will be used as a drill guide so additional spacers and hardware will be added later.

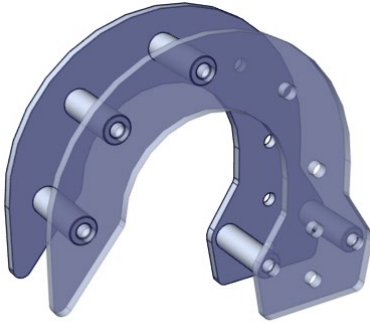

Step 2: Insert a 10-32 x 1.5" SHCS (am-1014) through both plates and spacers and secure with 10-32 Nylock Jam Nuts (am-1063).

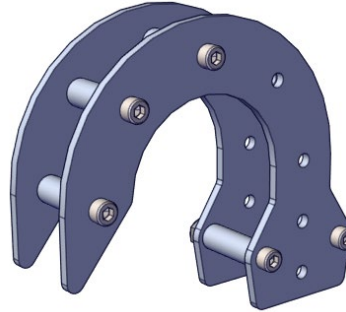

Pre-Assemble Winch Plates

Winch plates will be installed on the outer-most box tube. The winch plate assemblies are also used as drill guides for the box tubes.

Step 1: Align winch plates (am-4646) and 4 spacers (am-1599 or am-1600) as shown.

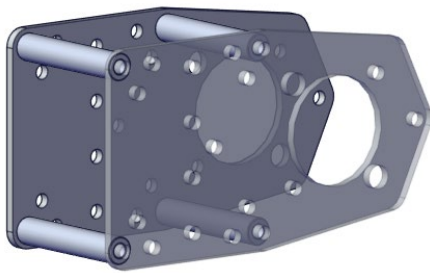

2.0" Box Tube – 2 Stage Assembly

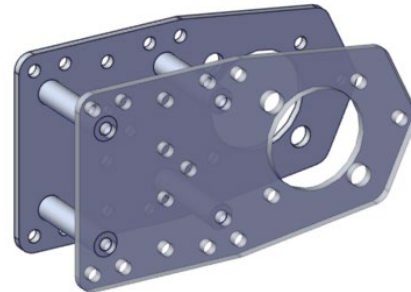

1.5" Box Tube – 1 Stage Assembly

Step 2: Loosely add 10-32 screws and nuts (am-1063) to the assembly.

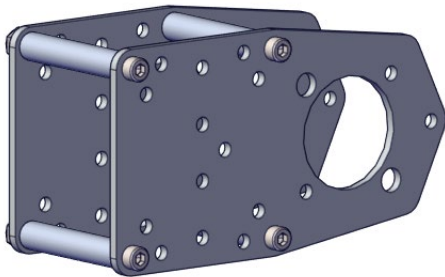

2.0" Box Tube – 2 Stage Assembly

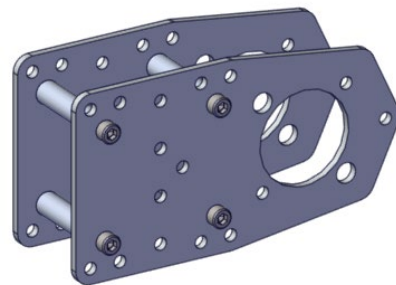

1.5" Box Tube – 1 Stage Assembly

Pre-Assemble 1.5" Bearing Plates

Leave hardware loose! Bearing plate assemblies will be used as drill guides for the box tubes.

Step 1: Align 1.5" tube bearing plates (am-4644) and 4 spacers (am-1599) as shown.

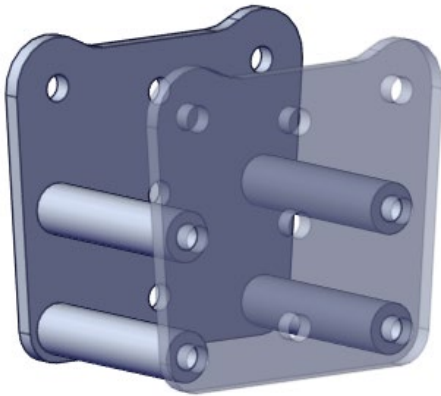

Step 2: Loosely add 10-32 screws (am-1049) and nuts (am-1063) to the assembly.

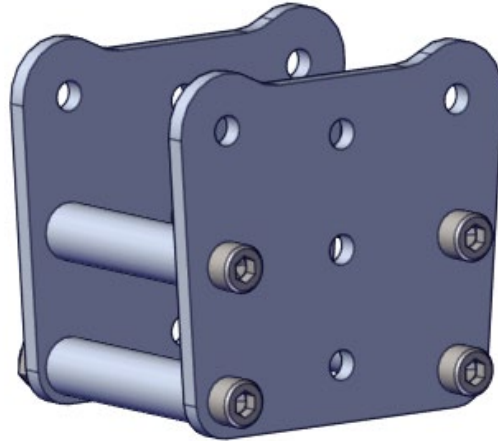

Pre-Assemble 2.0" Bearing Plates (2 Stage ONLY)

Leave hardware loose! Bearing plate assemblies will be used as drill guides for the box tubes.

Step 1: Align 2.0" tube bearing plates (am-4645) and 4 spacers (am-1600) as shown.

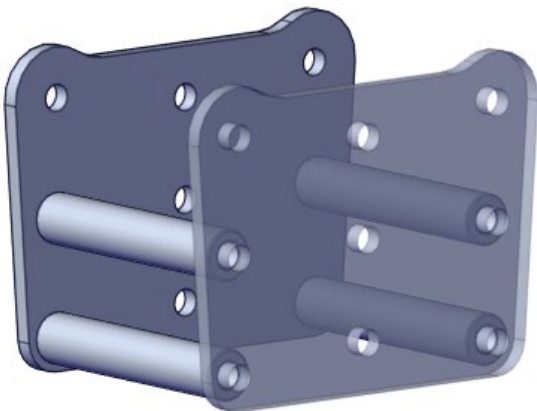

Step 2: Loosely add 10-32 screws (am-1024) and nuts (am-1063) to the assembly.

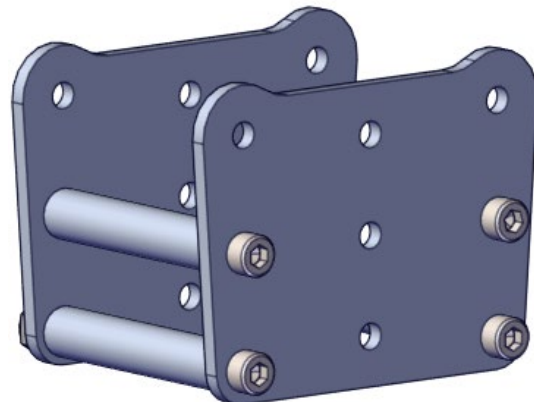

Tube Hole Locations for Match Drilling

Tips for drilling: Keep drill bit straight and perpendicular to the tube surface.
Make sure not to push too hard and bend the tube surface.
Ensure all chips and burrs are removed from the inside and outside of the tube after drilling.

Ensure all tubes are cut to length before drilling.

Below are images of how the tubes should look after drilling holes. Read further for full match drilling instructions.

CAD files and prints are also available on our website for more details.

1" Box Tube for 1 & 2 Stage Climbers

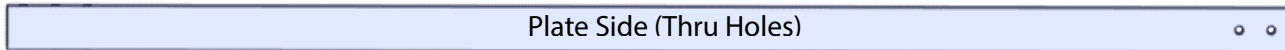

1.5" Box Tube for 1 Stage Climber ONLY



1.5" Box Tube for 2 Stage Climber ONLY

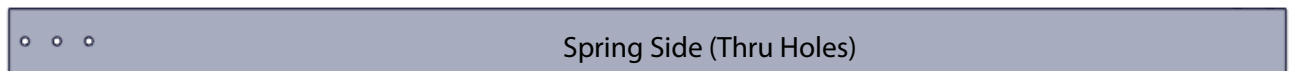
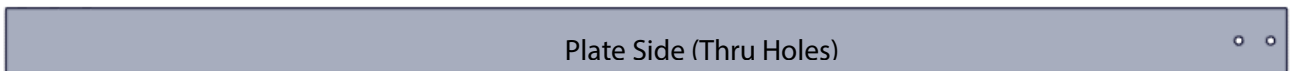

2" Box Tube for 2 Stage Climbers ONLY

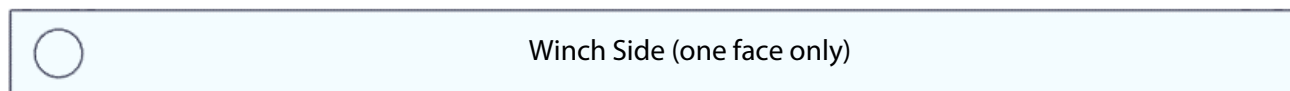

Drill 2.0" Box Tubes (2 Stage Only)

Tips for drilling: Keep drill bit straight and perpendicular to the tube surface.
Make sure not to push too hard and bend the tube surface.
Ensure all chips and burrs are removed from the inside and outside of the tube after drilling.

Step 1: Align the flat edge of the bearing plate with the edge of the Box Tube.

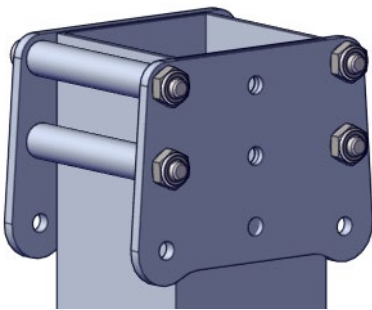

Step 2: Tighten screws to secure assembly.

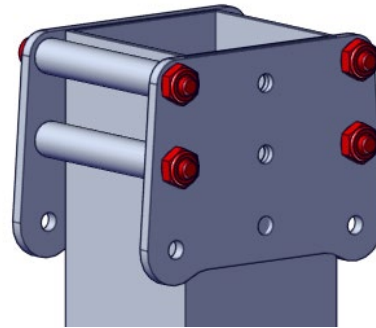

Step 3: Use a #7 .201" drill bit and drill two holes in the plate closest to the edge.

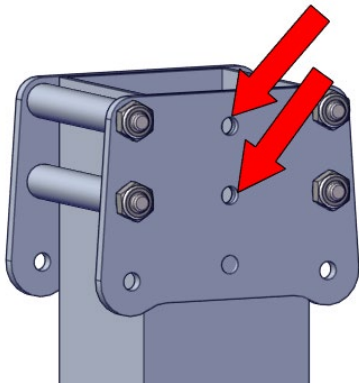

Step 4: Align the winch plate assembly to the other end of the tube. Use a #7 .201" drill bit and drill three holes on both sides. Ensure the offset hole aligns across the tube.

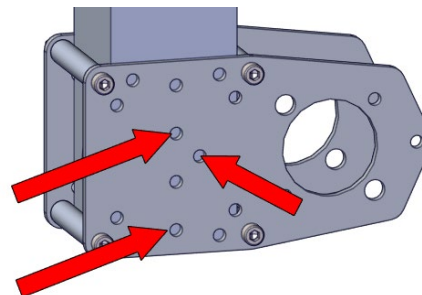

Step 5: Move the winch plate assembly to the face 90 degrees opposed to the faces with the holes drilled in the previous step. Use a #7 .201" drill bit and drill in the center hole on ONE side.

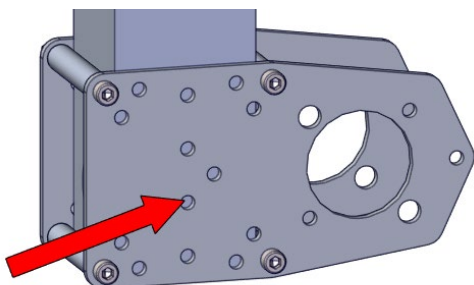

Step 6: Using a step drill bit, open up the hole in the tube to approximately 1.125" in diameter. The rope will pass through this hole so make sure the edges are deburred and smooth.

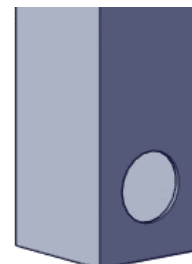

Drill 1.5" Box Tubes

Tips for drilling: Keep drill bit straight and perpendicular to the tube surface.

Make sure not to push too hard and bend the tube surface.

Ensure all chips and burrs are removed from the inside and outside of the tube after drilling.

Step 1: Align the flat edge of the bearing plate with the edge of the Box Tube.

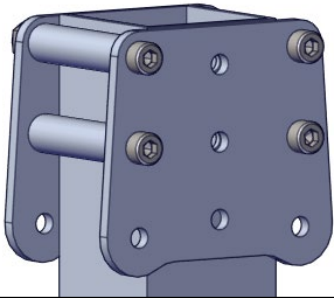

Step 2: Tighten screws to secure assembly.

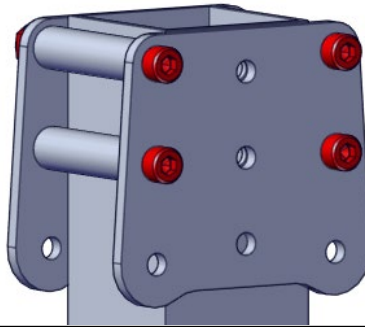

Step 3: Use a #7 .201" drill bit and drill two holes on both sides.

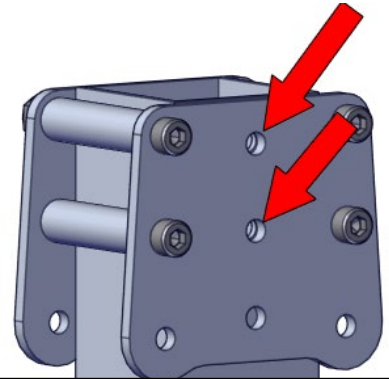

For 2-Stage Climbers drill the following additional holes in the 1.5" Box Tubes

Step 4a: Move the bearing plate assembly to the other end of tube and other face 90 degrees opposed to the faces with the holes drilled in the previous step. Use a #7 .201" drill bit and drill three holes on both sides.

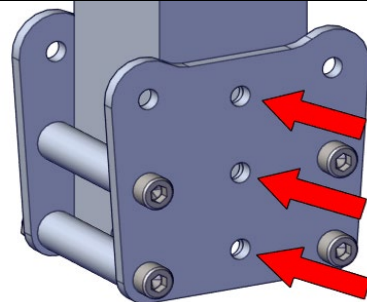

For 1-Stage Climbers drill the following additional holes in the 1.5" Box Tubes

Step 4b: Align the winch plate assembly to the other end of the tube. Use a #7 .201" drill bit and drill three holes on both sides. Ensure the offset hole aligns across the tube.

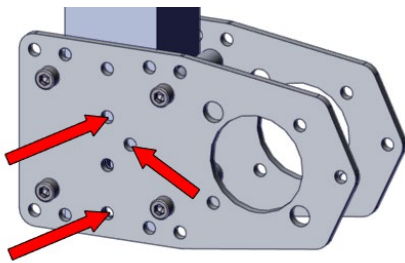

Step 5b: Move the winch plate assembly to the face 90 degrees opposed to the faces with the holes drilled in the previous step. Use a #7 .201" drill bit and drill in the center hole on ONE side.

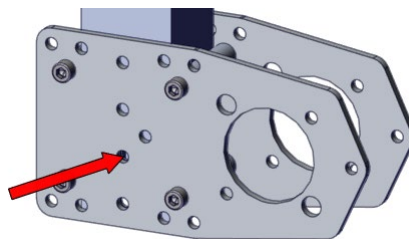

Step 5c: Using a step drill bit, open up the hole in the tube to approximately 1.125" in diameter. The rope will pass through this hole so make sure the edges are deburred and smooth.

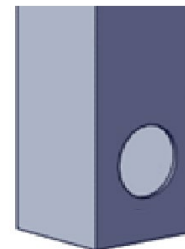

Drill 1.0" Box Tubes

Tips for drilling: Keep drill bit straight and perpendicular to the tube surface.

Make sure not to push too hard and bend the tube surface.

Ensure all chips and burrs are removed from the inside and outside of the tube after drilling.

Step 1: Align the flat edge of the hook assembly with the edge of the 1.0" Box Tube. Tighten screws and use a clamp to secure the hook to the tube.

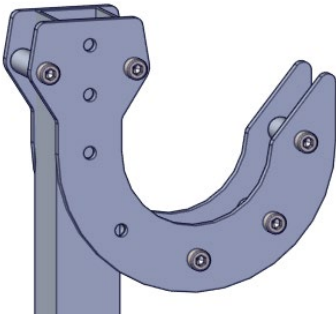

Step 2: Use a #7 .201" drill bit and drill two holes on both sides.

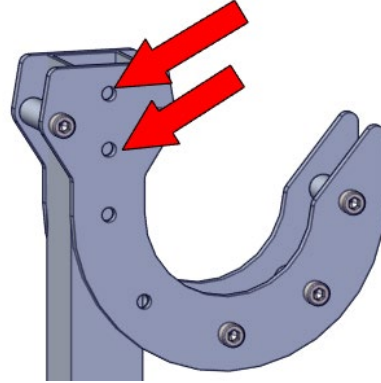

Step 3: Move the hook assembly to the other end of the tube other face 90 degrees opposed to the faces with the holes drilled in the previous step. Use a #7 .201" drill bit and drill two holes on both sides.

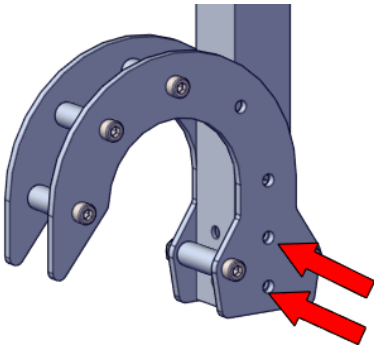

Step 4: Move the hook assembly up one hole and secure. Use a #7 .201" drill bit and drill a third hole in-line with the first two holes on both sides.

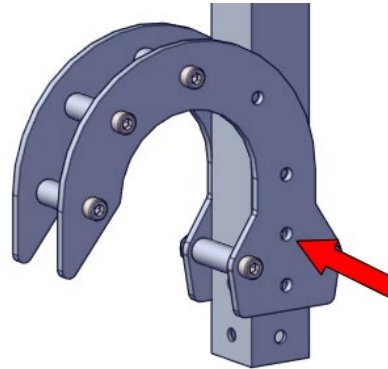

Assembly

Step 1: Screw the springs (am-4657) into the 1.0" tube using 10-32 x.375 patch screws (am-1585) and Nylock Nuts. (am-1063) The head of the screw should be on the same side as the coil. The screw should be snug, but not too tight and the spring needs to be parallel to the edges of the tube.

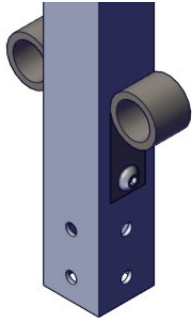

Warning: Springs are sharp be careful when uncoiling and handling

Step 2: Attach clamp blocks (am-4630). The top holes use 10-32 flat head screws (am-1505) and Nylock Nuts. (am-1063).

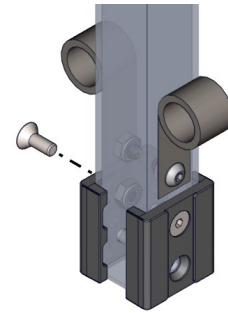

Note: Climber kits sold prior to 2/1/2022 may have two standoffs for mounting clamp blocks.

Step 3: In the bottom holes use 10-32 flat head screws (am-1505) and thread into a **standoff** (am-1613). Tie rope around the bottom standoff using a secure knot. To secure the knot it's helpful to carefully melt the knot and end with a lighter.

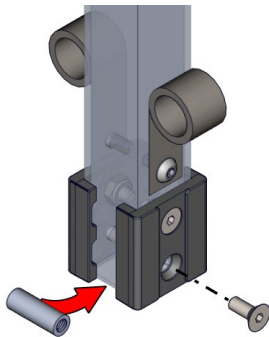

It may be helpful to use a wrench to hold the standoff in place while inserting the screw.

Step 4: Attach spring and clamp blocks (am-4631) to the **1.5" tube** using 10-32 flat head screws (am-1505) and Nylock Nuts. (am-1063).

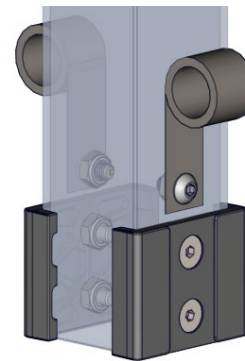

Step 5: Attach the Bearing Plate Assembly to the top of the 1.5" Tube using one 10-32 x 0.375" Button Head Cap Screws with thread patch (am-1588), Washers (am-1026) and non-locking nuts (am-1612) in the lower hole.

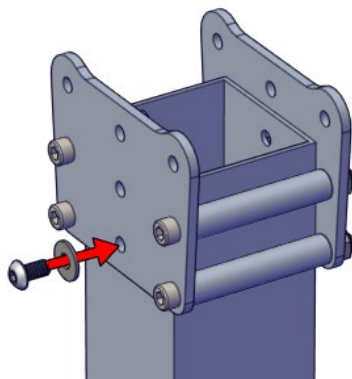

Step 6: Insert the 1.0" tube end into the 1.5" tube so that the springs align with the top holes in the Bearing Plates.

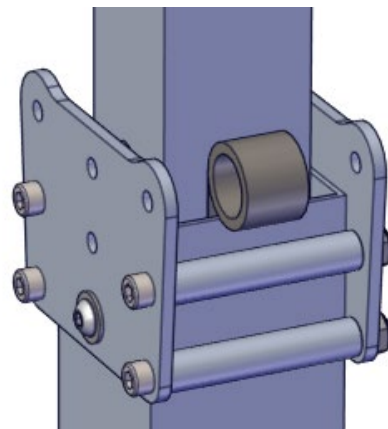

Step 7: Carefully insert two non-locking nuts (am-1612) – one into each slider block pocket as shown. Slide the slider block between the two extrusions with the nuts facing in as shown.

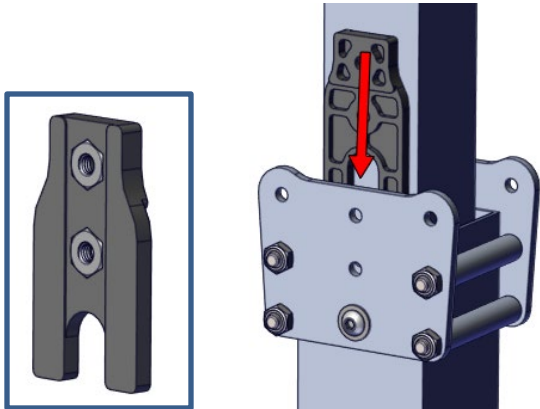

Step 8: Secure Inside slider blocks (am-4629) and Bearing Plate Assembly to the top of the 1.5" Tube using 10-32 x 0.375" Button Head Cap Screws with thread patch (am-1588), Washers (am-1026)

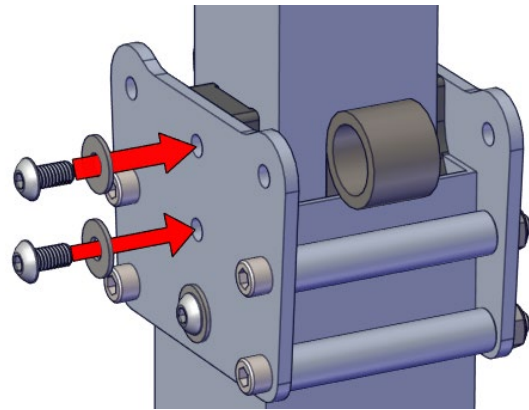

Step 9: Assemble the spacers, washers, and bearings through and alongside the spring as shown.

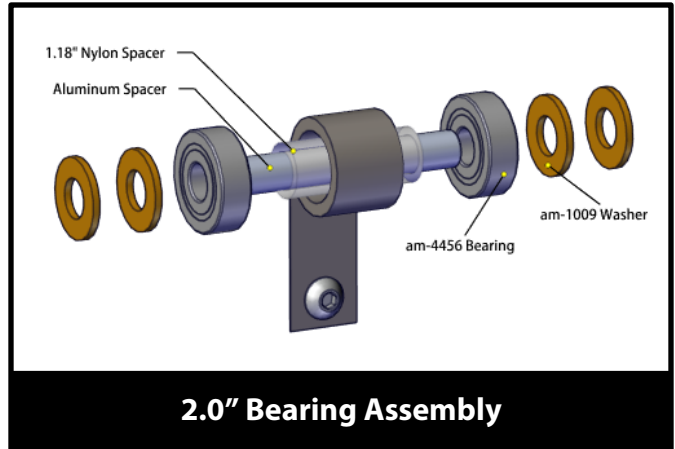
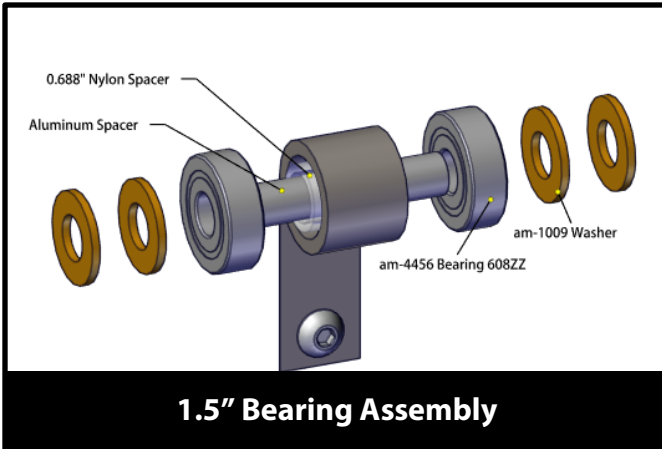

Step 10: Insert a 10-32 x 2" screw through the plates and assembly and secure with a nylock nut.

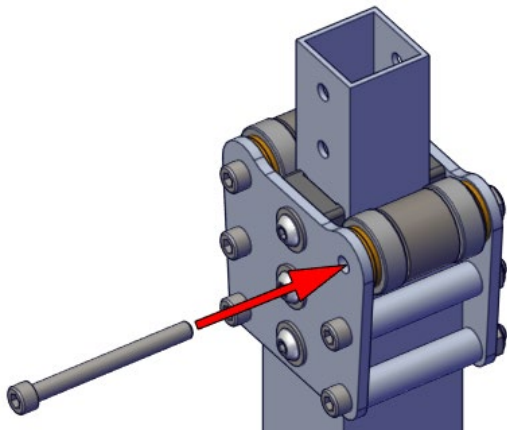

Step 11: For the 2-stage climber, insert the end of the 1.5" tube assembly into the 2.0" tube and repeat steps 1-9 to attach the bearings and plates to the 1.5" tube.

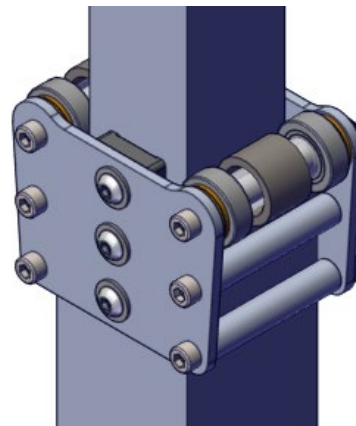

Step 12: Attach the winch plate assembly to the outer stage tube using 10-32 button head screws and nuts.

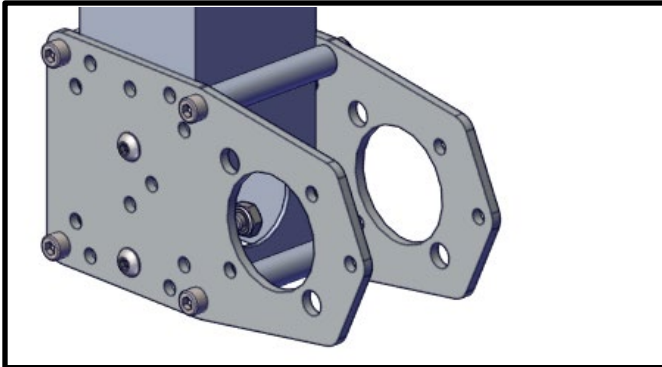

2.0" Winch Attachment

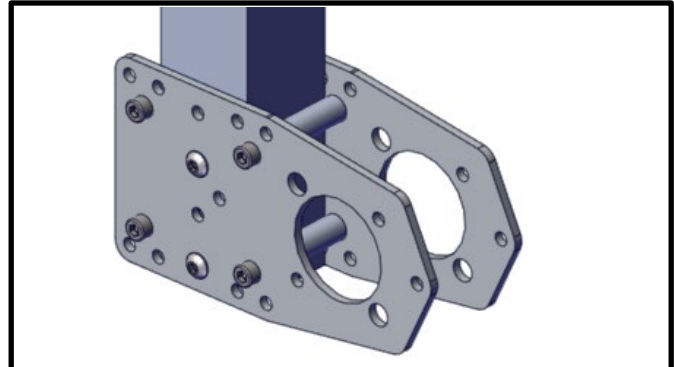

1.5" Winch Attachment

Step 13: Insert 10-32 x 2.5" screw through plate, tube and a spacers. This will help guide the rope through the hole to the spool.

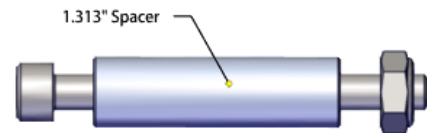
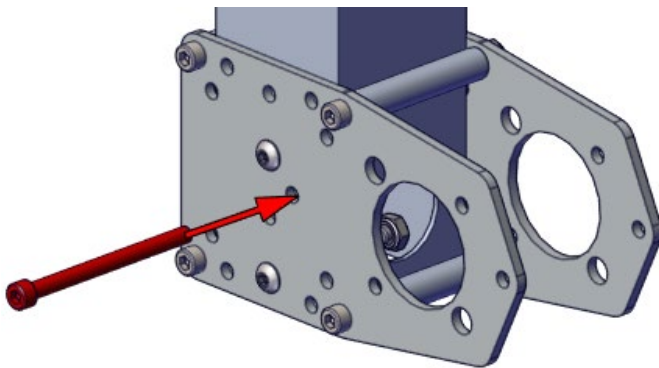

1.5" Winch Rope Guide

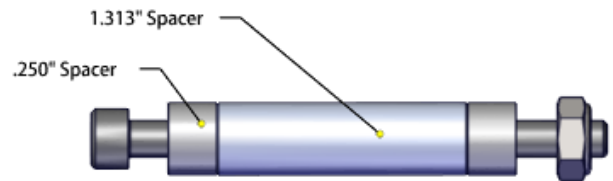

2.0" Winch Rope Guide

Step 15: Press a bearing into the bearing plate and attach to the plate using 10-32 button head screws and nuts. Make sure the bearing flange is on the inside face of the plate so the bearing does not fall out during operation.

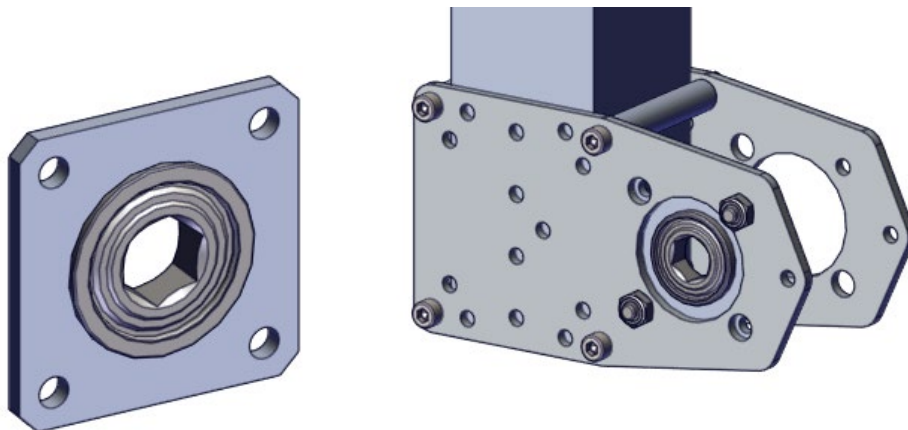

Step 17. Secure the rope to the spool and add your gearbox to the assembly. The shaft of your gearbox should extend through both bearings.



Step 18. Add another spacer and secure with 10-32 screw and nut.

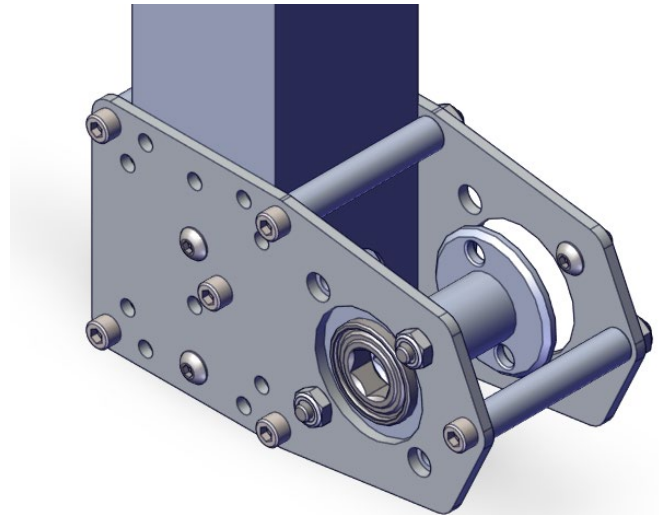

For more tips and video on how to choose a gearbox and tie your rope visit our website.

Step 19. Add remaining spacers and screws to complete the hook assembly.

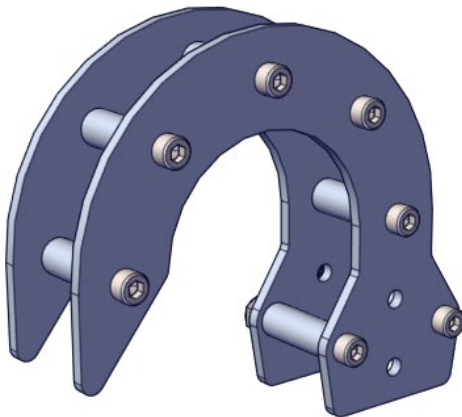

Step 20. Attach hook to 1.0" box tube using 10-32 screws and Nylock Nuts.

