

REVISION HISTORY			
REV.	DESCRIPTION	DATE	DRAWN BY
1	ORIGINAL PRINT	11/28/2023	P. YEUNG
2	REVISED HOLE SIZE FOR MFG TOLERANCE STACKUP	12/15/2023	P. YEUNG

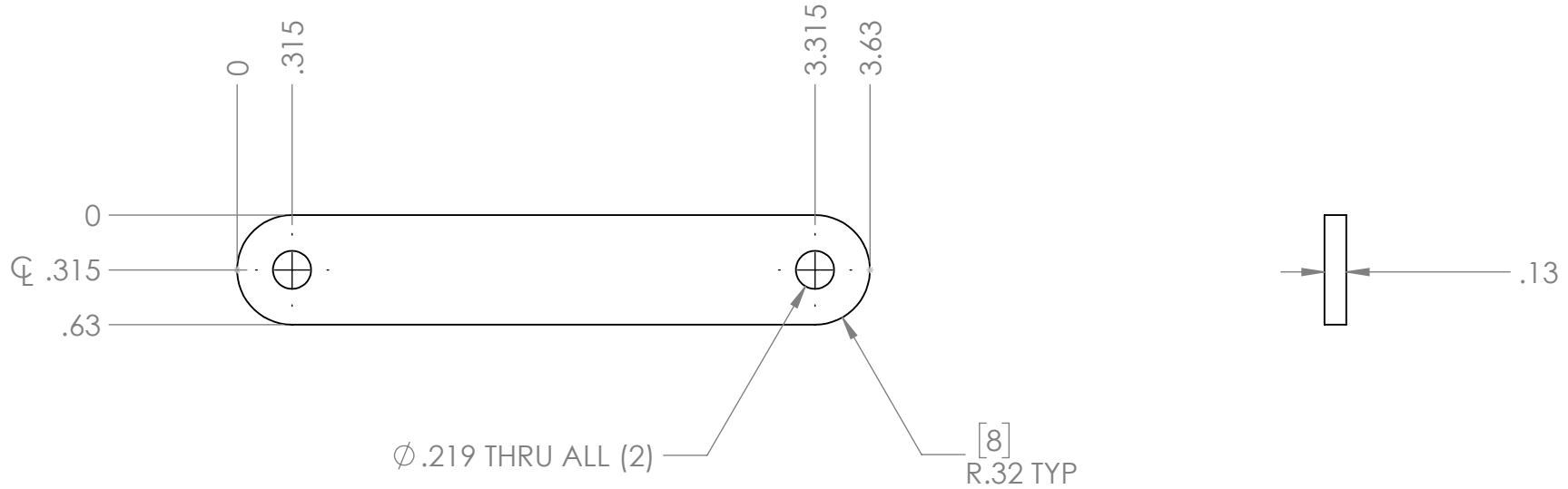

\*\*\* SEE CAD FOR ADDITIONAL TOOLPATH INFO\*\*\*

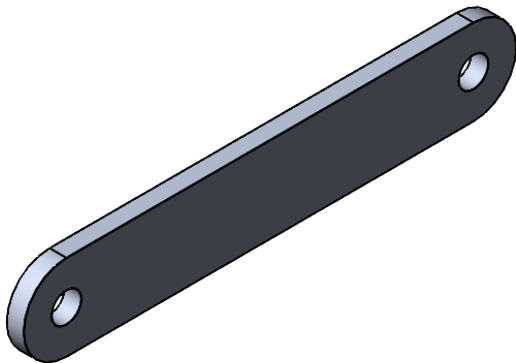

UNLESS OTHERWISE SPECIFIED:		COMMENTS:					
<b>DIMENSIONS ARE IN INCHES</b>		DUAL DIMENSIONS ARE IN MILLIMETERS.					
TOLERANCES: FRACTIONAL $\pm 1/16$ ANGULAR: MACH $\pm 1^\circ$ ANGULAR: BEND $\pm 5^\circ$ ONE PLACE DECIMAL $\pm 0.1$ TWO PLACE DECIMAL $\pm 0.01$ THREE PLACE DECIMAL $\pm 0.005$ FOUR PLACE DECIMAL $\pm 0.0005$		BREAK ALL SHARP EDGES.		TITLE:			
MATERIAL AL 6061-T6				Belt Welder Lower Plate			
FINISH DEBURRED		CHECKED	NAME NM	DATE	SIZE <b>A</b>	DWG. NO. am-5282	REV 2
DO NOT SCALE DRAWING		ENG APPR.			SCALE: 1:1		SHEET 1 OF 1
		MFG APPR.					
		Q.A.					