

# **AndyMark**<sup>®</sup>

## **Robot Parts Cart**

(am-5230)

*Assembly Guide*



Revision #	Date	Author	Purpose
0	04/29/2024	E. Clark, E. Scime	Original Document

N. Massouda	5/13/2024
_____ Reviewer	_____ Date Reviewed

Need help with an AndyMark product? Contact us at [support@andymark.com](mailto:support@andymark.com) or (877)-868-4770.

## Parts & Tools

### Recommended Tools List

Component	Part #	QTY	Photo
3/8in Nut Driver	am-3877	1	
5/32in Ball End Hex Driver	am-2751	1	
1/8in Ball End Hex Driver	am-2750	1	
1/2-9/16 Open-End Wrench	am-2746	1	
3/8-7/16 Open-End Wrench	am-2745	1	
Hand Rivet Tool	am-2834	1	
3/8in Magnetic Nutsetter	am-2755	1	
Drill	N/A	1	









## Parts List

Component	Part #	QTY	Photo
Organizer Container with 15 Adjustable Compartments	am-4972	8	
4 in Caster Assembly	am-2799	2	
4 in Caster Assembly with Break	am-4989	2	
Surface Latch	am-4973_latch am-4973_plate	2 2	
17 5/16 in. Long Churro Extrusion	am-5218	8	
3/16 in. Diameter 0.126 to 0.25 in. Grip Range Steel Rivet	am-1226	50	
1/4 – 20 x 0.75 in. Self Tapping Hex Washer Head Screw	am-1310	25	

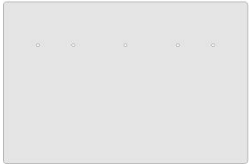

Component	Part #	QTY	Photo
1/4 – 20 x 1.75 in. Thread Forming Screw	am-1372	8	
10-32 x 5/8 Button Head Cap Screw with Nylon Patch	am-1549	4	
10-32 x 1 in. Flat Head Cap Screw	am-1324	14	
10-32 Nylock Jam Nut	am-1063	18	
1/4 – 20 x 1 in. Button Head Cap Screw	am-1525	16	
1/4" Washer	am-1027	16	
1/4 – 20 Nylock Jam Nut	am-1102	16	

Component	Part #	QTY	Photo
Robot Parts Cart Wood Top	am-5230_top	1	
Robot Parts Cart Shelf	am-5230_shelf	19	
Robot Parts Cart Battery Tray Polycarbonate	am-5230_tray	3	
Robot Parts Cart Peanut Leg	am-5230_leg	4	
Robot Parts Cart Diamond Plate Base	am-5230_base	1	
Robot Parts Cart Battery Tray Polycarbonate	am-5230_spacer	4	

# Assembly

## Step 1

Align the Robot Parts Cart Shelf (am-5230\_shelf) with two Robot Parts Cart Peanut Legs (am-5230\_leg) as shown and attach them using two rivets (am-1226). From the "top" of the cart, place shelves every other set of holes, starting with the second hole down on one side and the third hole down on the other.

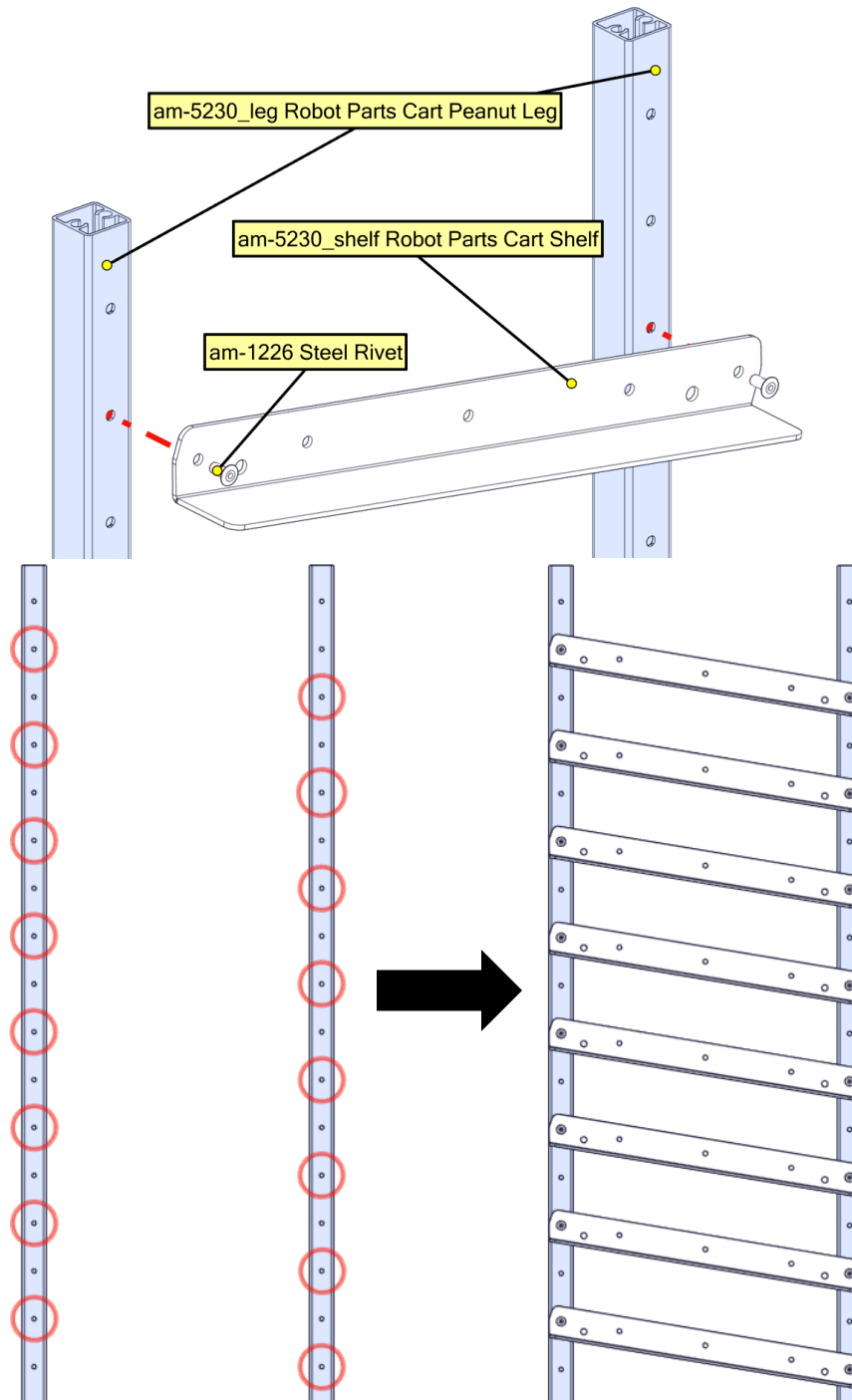

Step 2

Repeat Step 1, but mirror the placement of each shelf as shown.

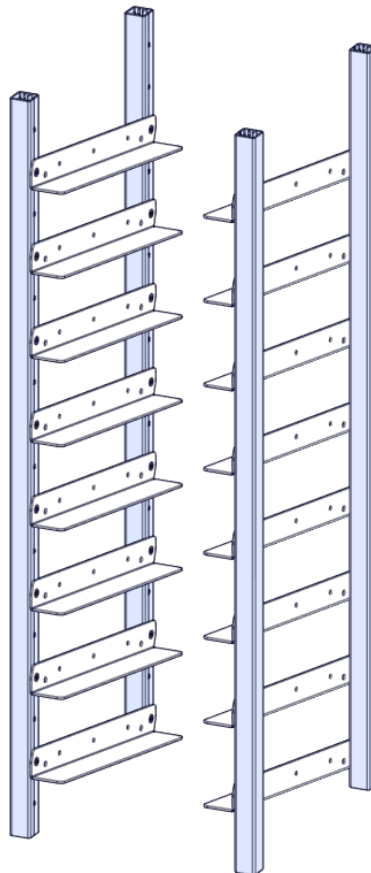
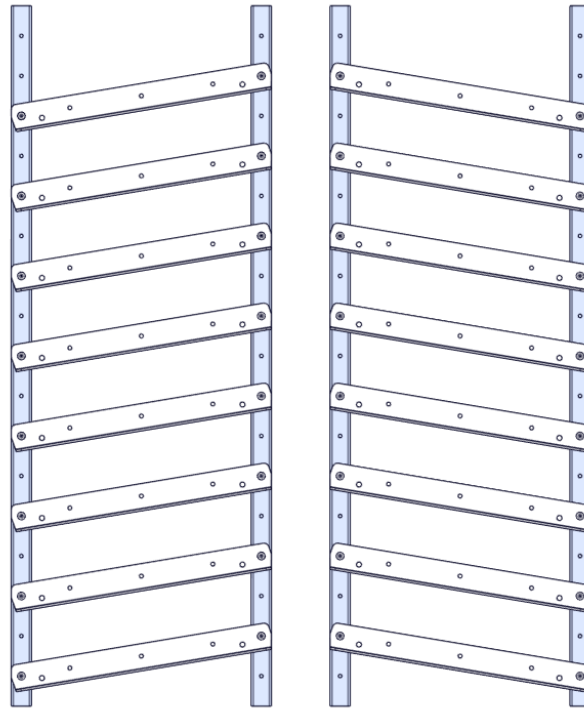



**Step 3** **OPTIONAL – FOR USE WITH MULTIPLE CARTS:**

Attach the Surface Latches (am-4973) to the underside of the Robot Parts Cart Top Plate (am-5230\_top) using 10-32 1" Flat Head Cap Screws (am-1324) and 10-32 Nylock Jam Nuts (am-1102).

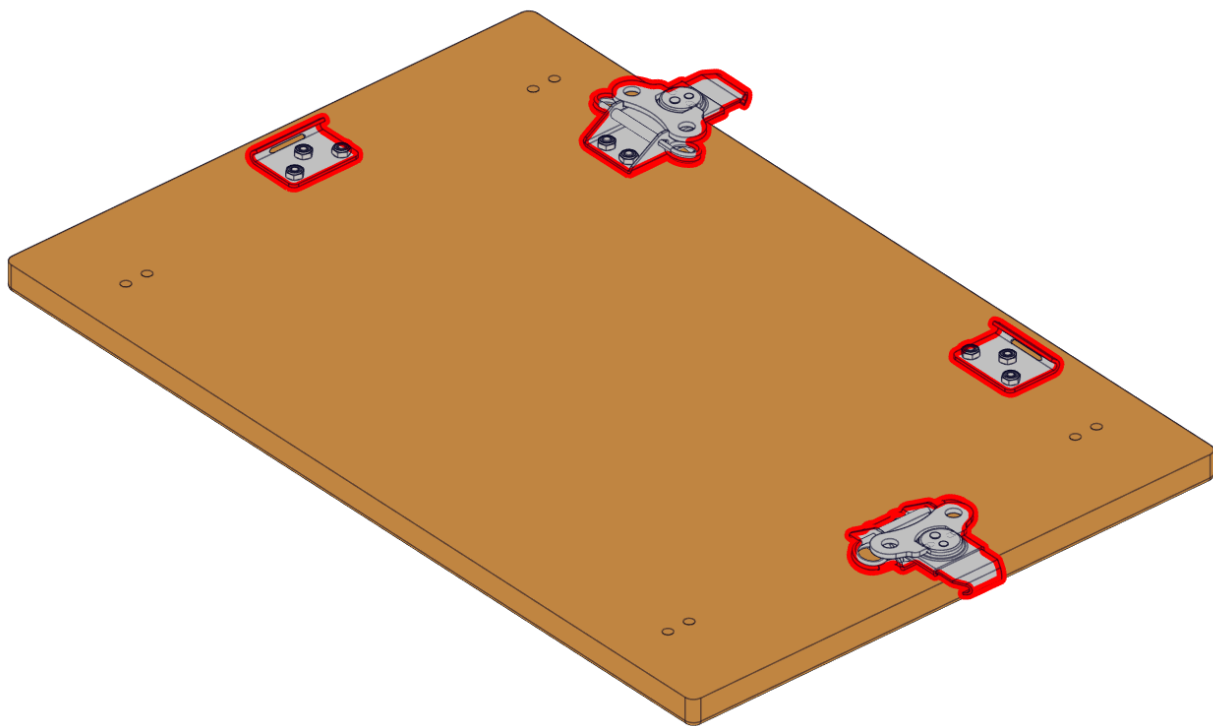
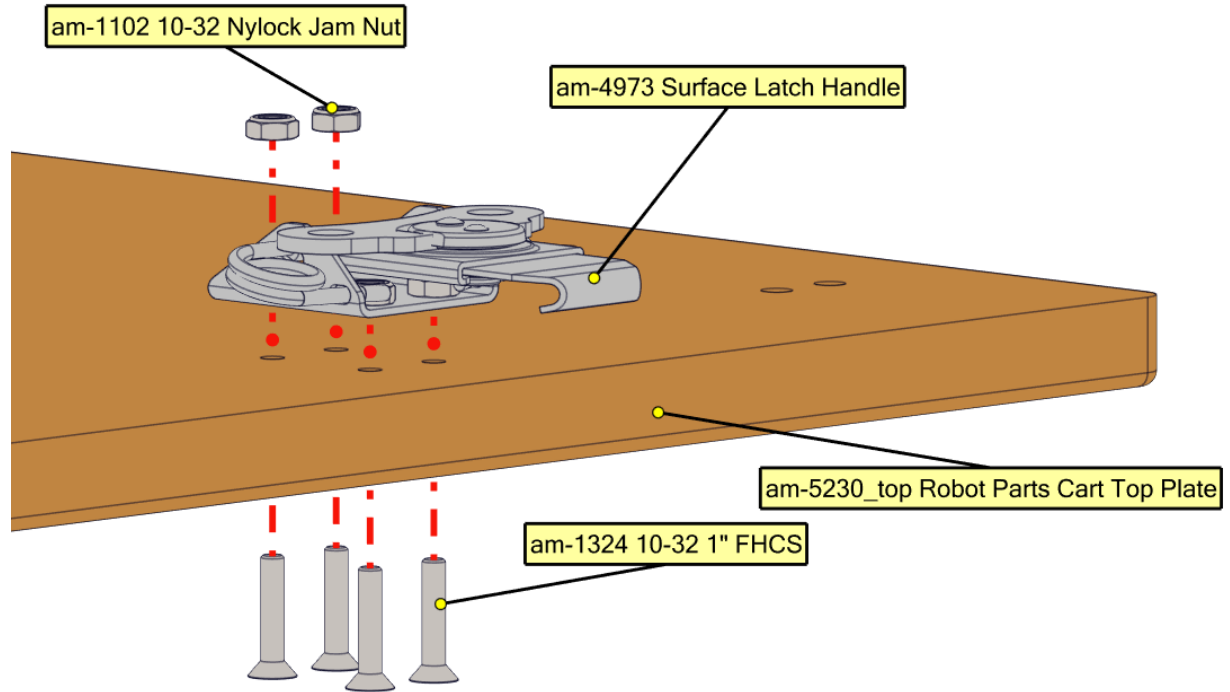

**Step 4**

Attach the assemblies from Step 2 to Top Plate (am-5320\_top) using eight 1/4-20 1-3/4" long Threadforming screws (am-1372). The shelves should face towards each other as shown.

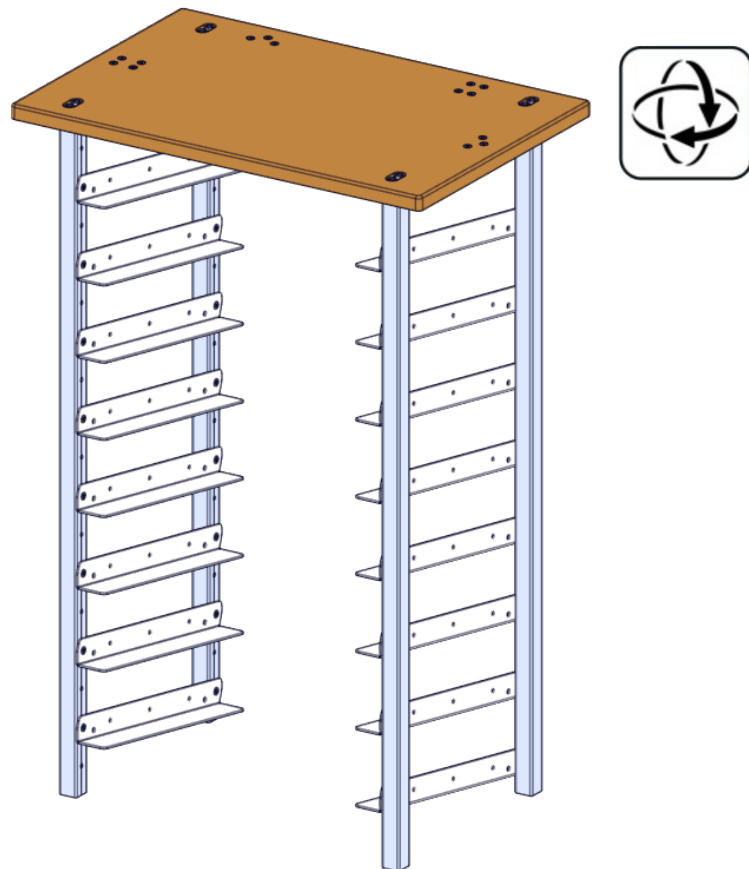
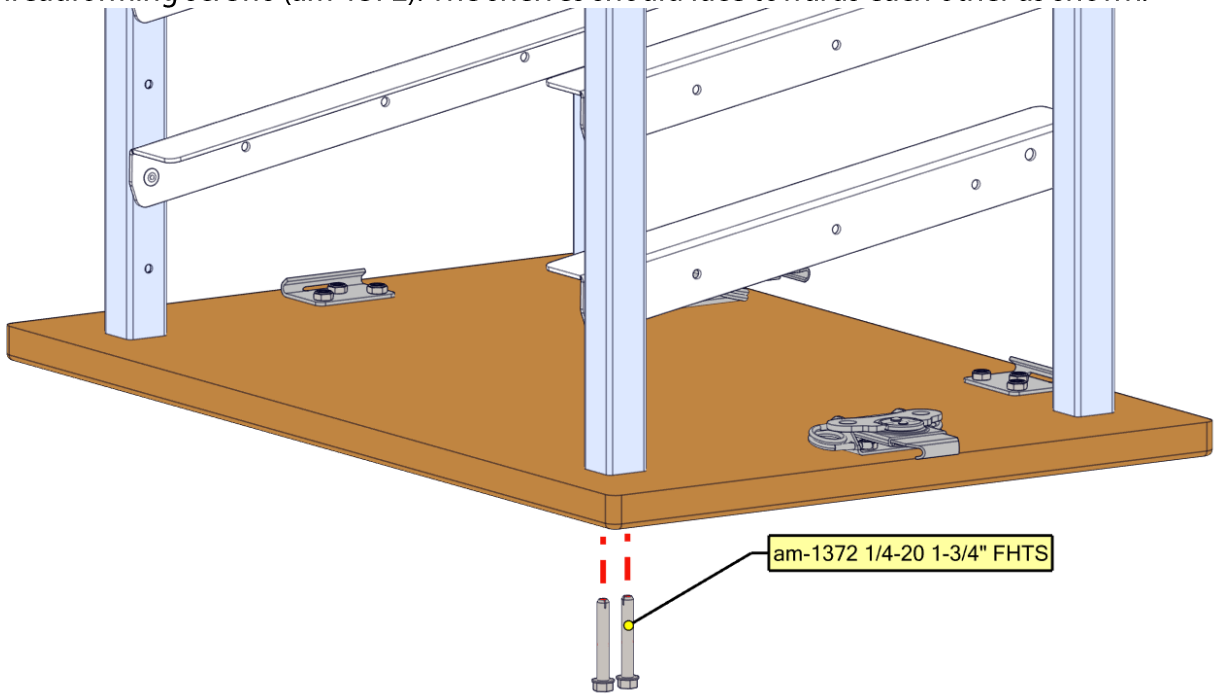

**Step 5**

Attach the Base Plate (am-5320\_base) to the assembly using eight 1/4-20 3/4" Threadforming screws (am-1310). The tread pattern should face up towards the wood top of the assembly.

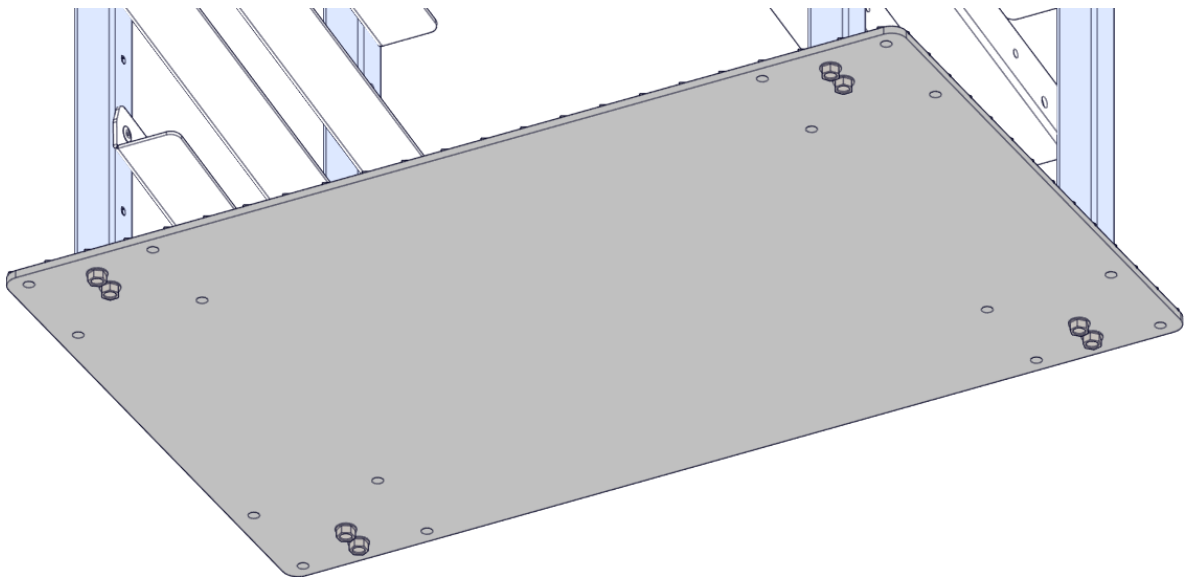
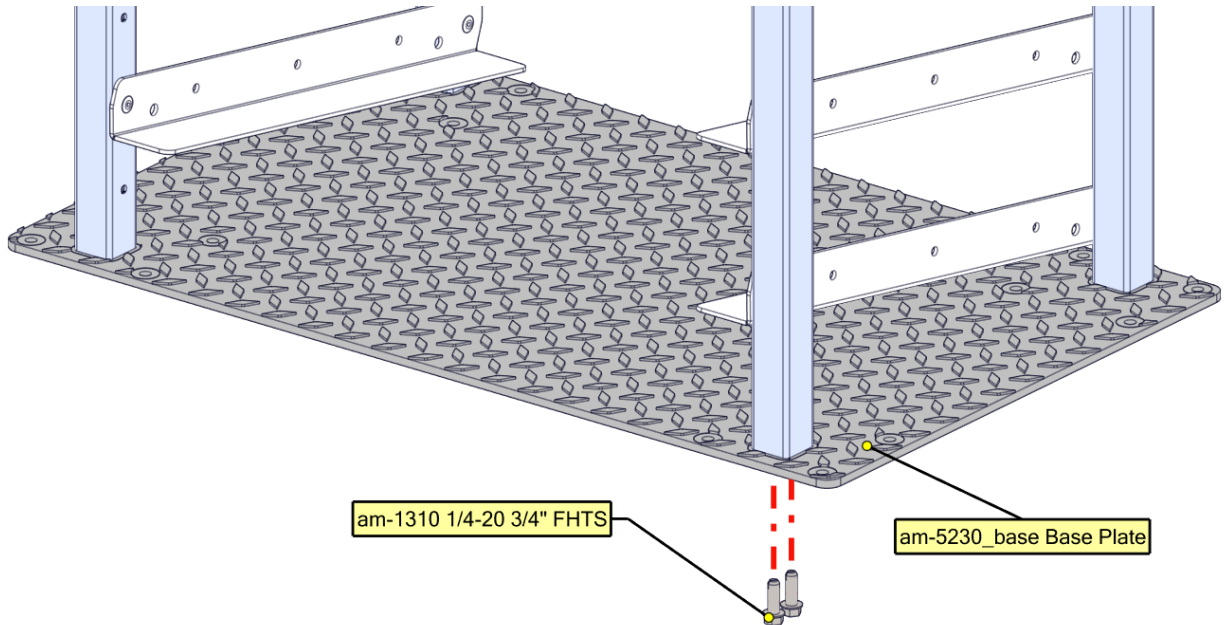

**Step 6**

Attach a 4" Caster (am-2799) to one of the corners of the cart with the raised side of the shelves using four 1" 1/4-20 Button Head Cap Screws (am-1525), four 1/4" washers (am-1027), and four 1/4-20 nylock nuts (am-1015). Use a Caster Spacer (am-5230\_spacer) to properly space the Caster from the Base Plate, oriented as shown.

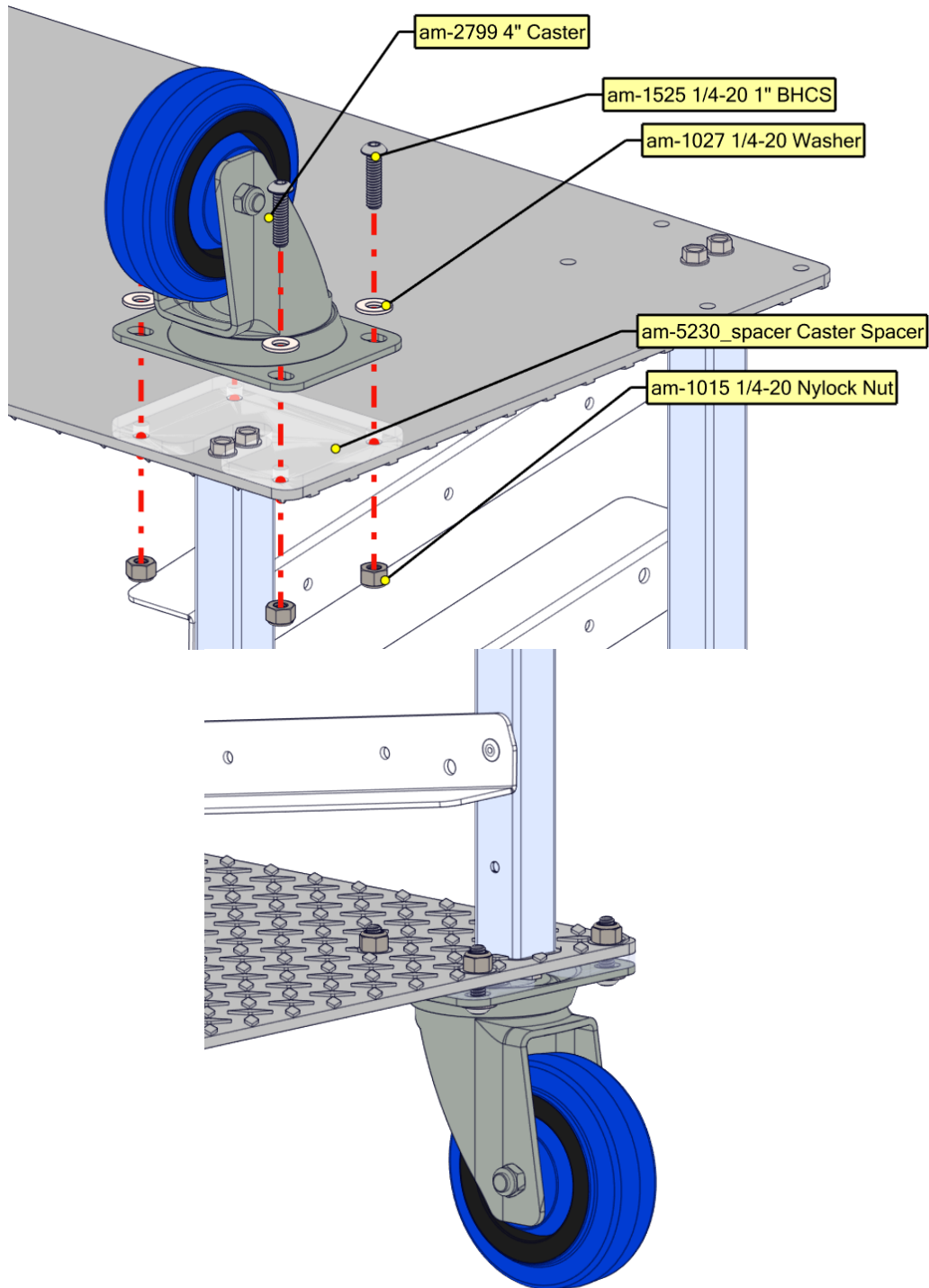

**Step 7**

Repeat Step 5 with the three remaining Casters. Ensure the remaining Caster without a brake is placed on the side with the raised end of the shelving.

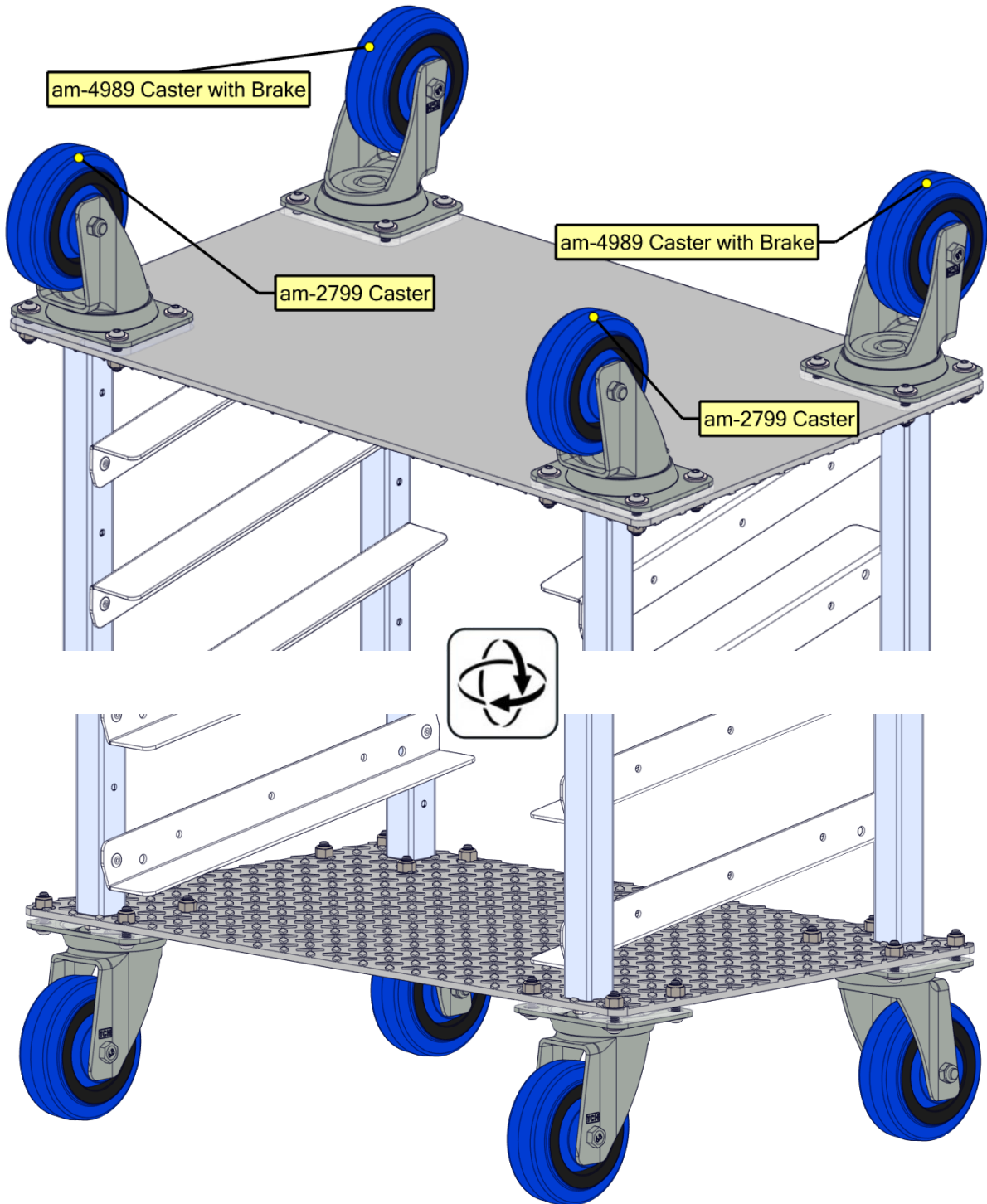

**Step 8**

Between the shelf sides of the cart, insert Churros (am-5218) up the length of the cart on the lowered side of each shelf, one per shelf, for a total of 8 Churros. Fasten in place with two 1/4-20 3/4" Threadforming screws (am-1310) each.

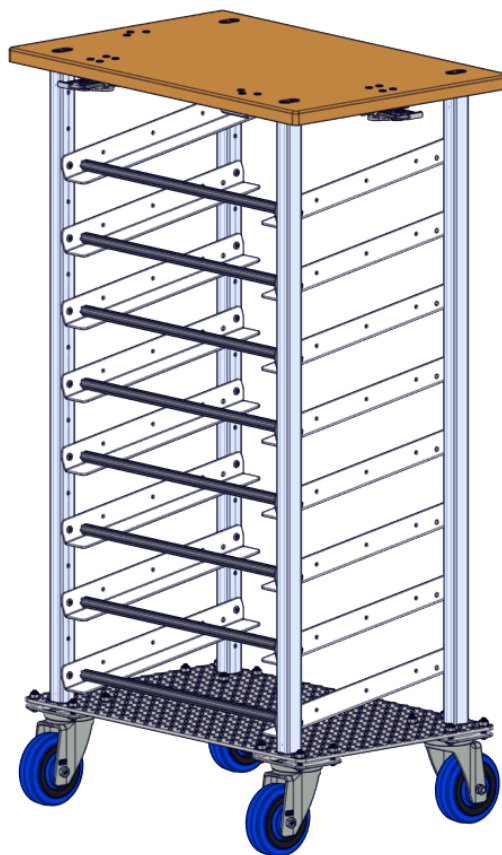
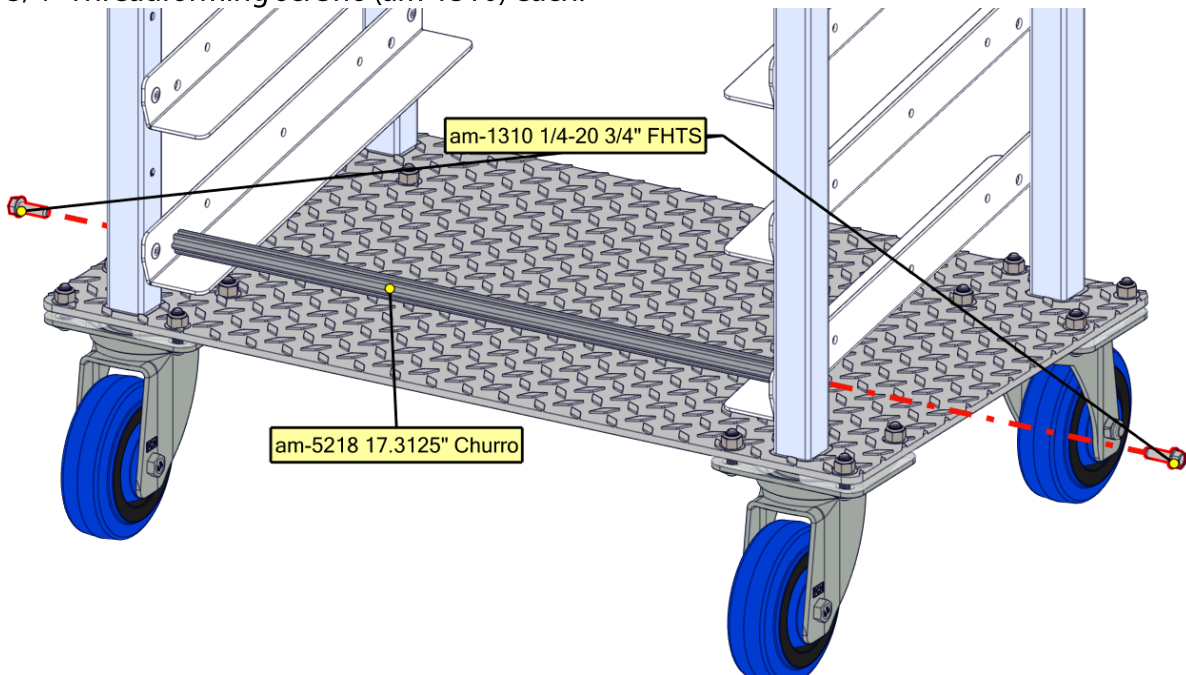

**Step 9** **OPTIONAL – FOR USE WITH FRC BATTERIES.**

Assemble three battery shelves by attaching a Robot Parts Cart Shelf (am-5230\_shelf) to each Battery Tray (am-5230\_tray) with five rivets (am-1226). Slip each tray into the bottom three shelves of the cart.

am-5230\_tray Battery Tray Polycarbonate

am-5230\_shelf Robot Parts Cart Shelf

am-1226 Steel Rivet

**3X**

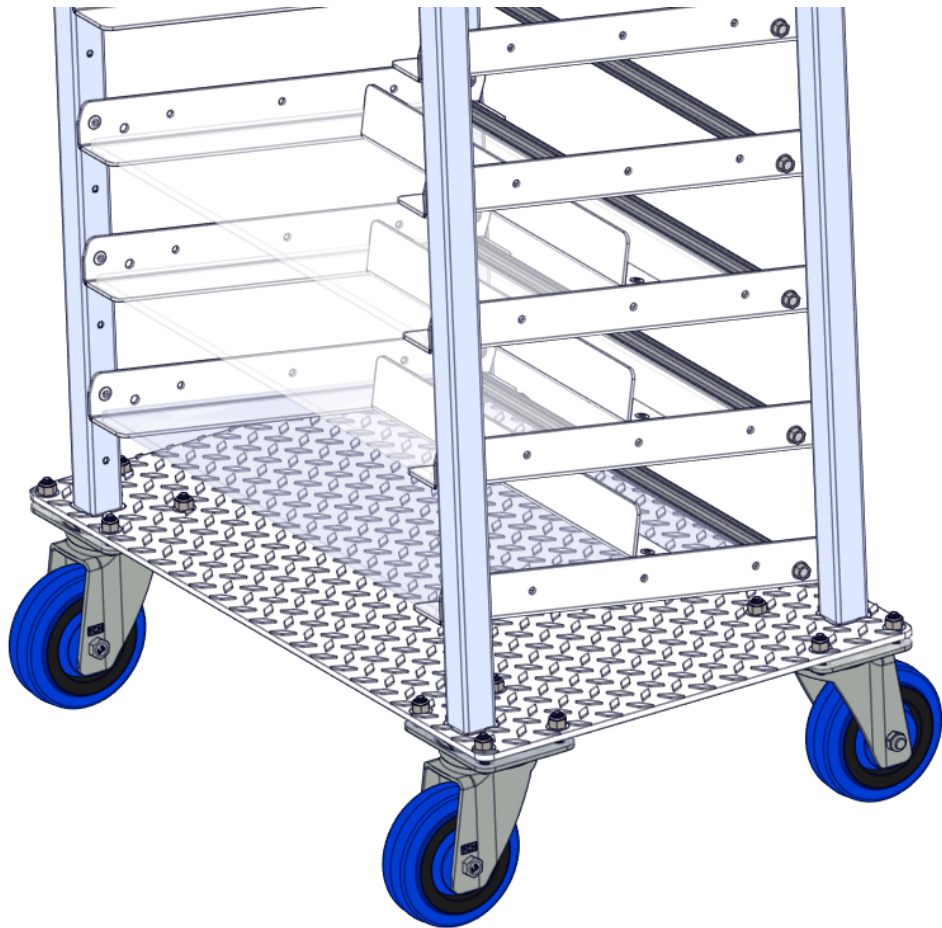

**Step 10** **OPTIONAL – FOR USE WITH NOCO BATTERY CHARGERS (AM-4968\_3 OR AM-5163\_3)**  
Install NoCo Battery Chargers (not included) using two 10-32 5/8" Button Head Cap Screws (am-1549) and two 10-32 Nylock Nuts (am-1063) on the side of any shelf.

