

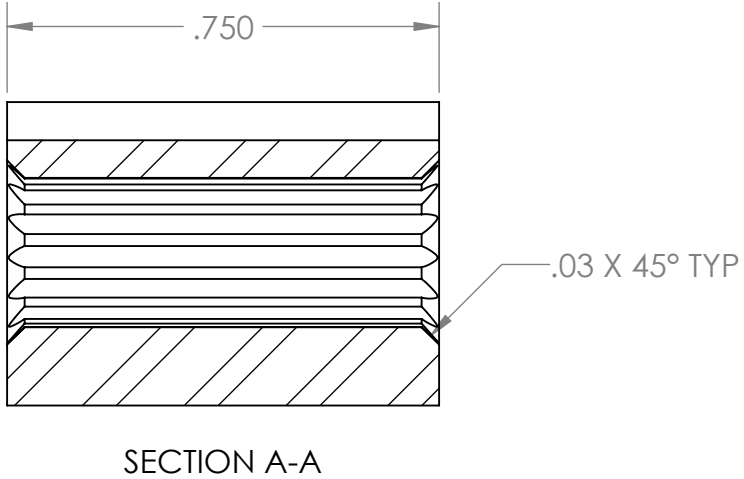

REVISION HISTORY			
REV.	DESCRIPTION	DATE	DRAWN BY
1	ORIGINAL PRINT	8/28/2019	N. MASSOUDA
2	UPDATED NOTES AND CHAMFERS	10/24/2019	N. MASSOUDA

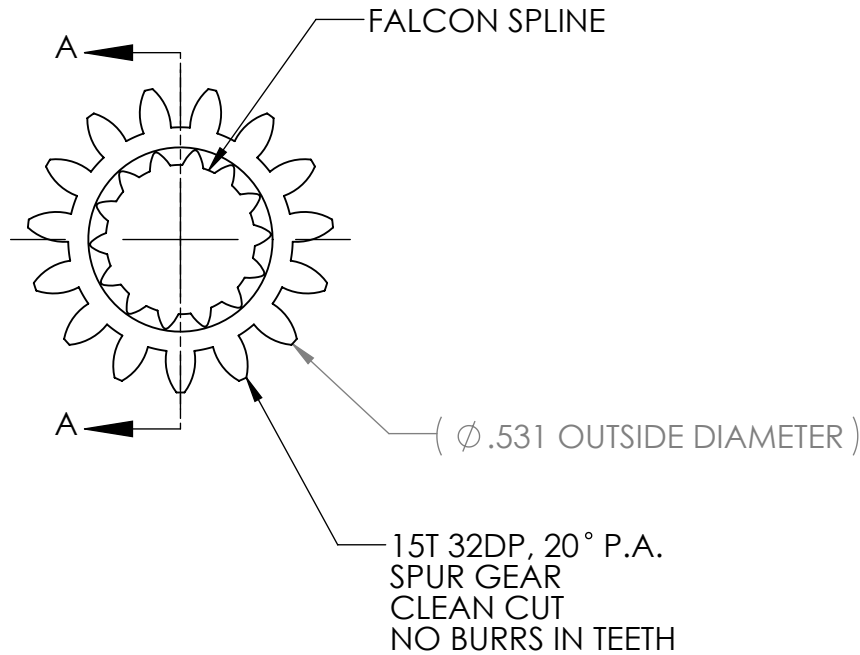

\*\*\* SEE CAD FOR ADDITIONAL TOOLPATH INFO\*\*\*

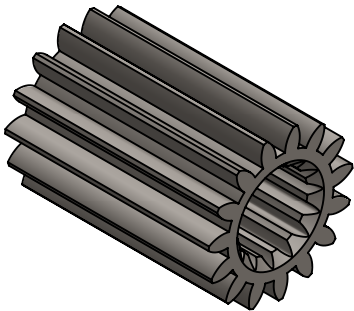

UNLESS OTHERWISE SPECIFIED:		COMMENTS:				
<b>DIMENSIONS ARE IN INCHES</b>		DUAL DIMENSIONS ARE IN MILLIMETERS.				
TOLERANCES:		BREAK ALL SHARP EDGES		SIZE	DWG. NO.	REV
FRACTIONAL	±1/16			<b>A</b>	am-4148	2
ANGULAR: MACH	±1°			SCALE: 3:1	WEIGHT:	SHEET 1 OF 1
ANGULAR: BEND	±5°					
ONE PLACE DECIMAL	±0.1					
TWO PLACE DECIMAL	±0.01					
THREE PLACE DECIMAL	±0.005					
FOUR PLACE DECIMAL	±0.0005					
MATERIAL	4140 STEEL	CHECKED	NAME	DATE		
FINISH	DEBURR & ZINC PLATE	ENG APPR.	NL	10/24/19		
		MFG APPR.				
	DO NOT SCALE DRAWING	Q.A.				