

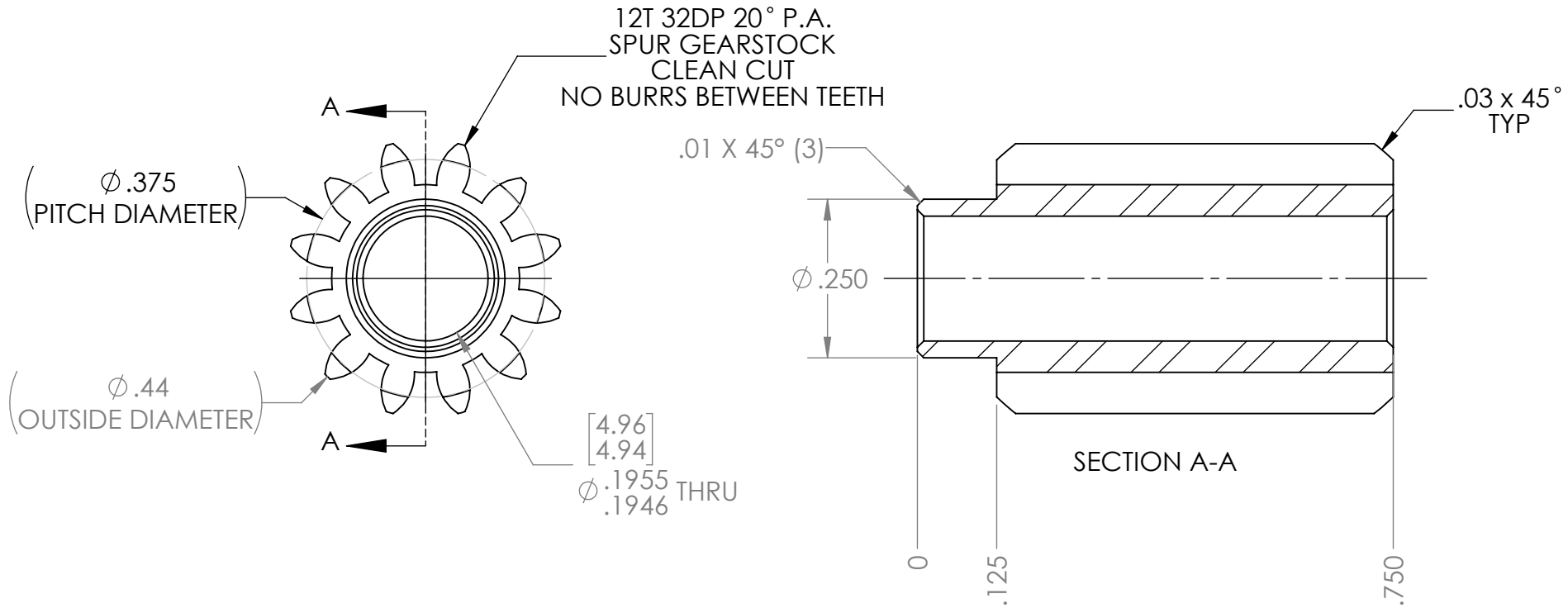

REVISION HISTORY			
REV.	DESCRIPTION	DATE	DRAWN BY
1	ORIGINAL PRINT	7/6/2017	J. ANG
2	UPDATED TO AMDS-1	10/5/2021	N. LAWRENCE
3	UPDATED DIMS & MATERIAL	6/14/2022	T. JORGENSEN

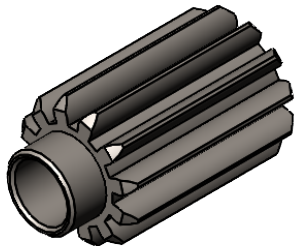

\*\*\* SEE CAD FOR ADDITIONAL TOOLPATH INFO\*\*\*



UNLESS OTHERWISE SPECIFIED:		COMMENTS:				
<b>DIMENSIONS ARE IN INCHES</b>		DUAL DIMENSIONS ARE IN MILLIMETERS.				
TOLERANCES:		BREAK ALL SHARP EDGES.		TITLE:		
FRACTIONAL	$\pm 1/16$			12T 32DP 20PA		
ANGULAR: MACH	$\pm 1^\circ$			5mm BORE GEAR		
ANGULAR: BEND	$\pm 5^\circ$			SIZE	DWG. NO.	REV
ONE PLACE DECIMAL	$\pm 0.1$			<b>A</b>	am-3657	3
TWO PLACE DECIMAL	$\pm 0.01$			SCALE: 4:1		
THREE PLACE DECIMAL	$\pm 0.005$			SHEET 1 OF 1		
FOUR PLACE DECIMAL	$\pm 0.0005$					
MATERIAL	STEEL: 1117, 4140	CHECKED	NAME	DATE		
FINISH	DEBURRED ZINC PLATED	ENG APPR.	NL	6/29/22		
DO NOT SCALE DRAWING		MFG APPR.				
		Q.A.				