

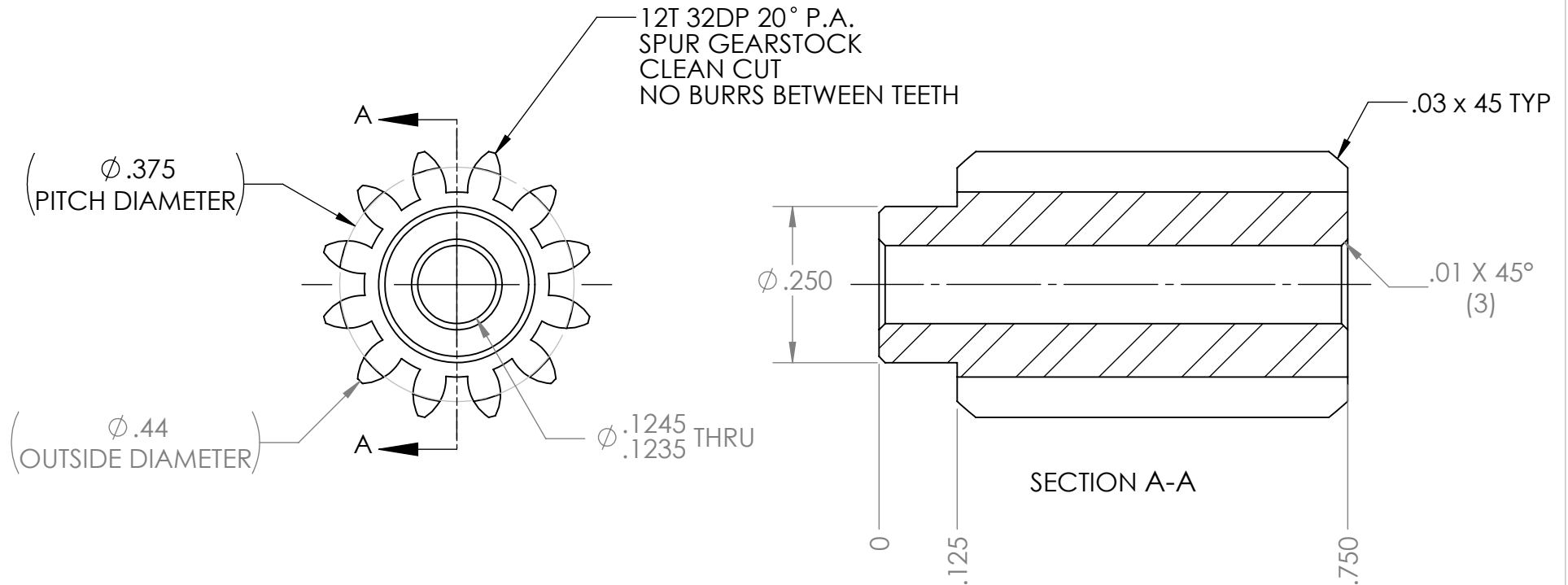

REVISION HISTORY			
REV.	DESCRIPTION	DATE	DRAWN BY
1	ORIGINAL PRINT	1/18/2019	N. MASSOUDA
2	UPDATED TO AMDS-1	2/28/2022	N. MASSOUDA
3	UPDATED CHAMFERS TO MATCH	6/29/2022	T. JORGENSEN

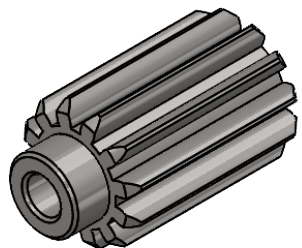

*** SEE CAD FOR ADDITIONAL TOOLPATH INFO***



UNLESS OTHERWISE SPECIFIED:		COMMENTS:			
DIMENSIONS ARE IN INCHES		DUAL DIMENSIONS ARE IN MILLIMETERS.			
TOLERANCES:		BREAK ALL SHARP EDGES		TITLE:	
FRACTIONAL	$\pm 1/16$			12T 32DP 20PA	
ANGULAR: MACH	$\pm 1^\circ$			125IN BORE GEAR	
ANGULAR: BEND	$\pm 5^\circ$			SIZE	DWG. NO.
ONE PLACE DECIMAL	± 0.1			A	am-4032
TWO PLACE DECIMAL	± 0.01			SCALE: 4:1	WEIGHT:
THREE PLACE DECIMAL	± 0.005			SHEET 1 OF 1	
FOUR PLACE DECIMAL	± 0.0005				
MATERIAL	STEEL: 1117, 4140	NAME	DATE		
FINISH	DEBURRED ZINC PLATED	CHECKED	NL	6/29/22	REV 3
		ENG APPR.			
		MFG APPR.			
	DO NOT SCALE DRAWING	Q.A.			