

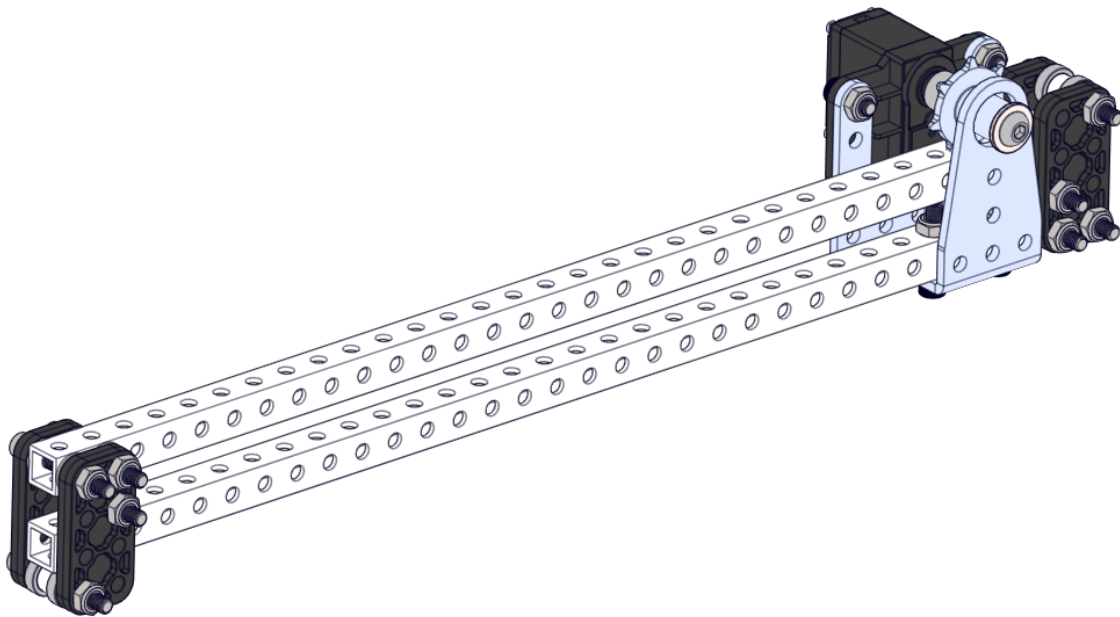

# ROBITS Cog Drive

(am-5519)

*Assembly Guide*





Revision #	Date	Author	Purpose
0	9/16/2024	Ethan Scime	Original Document

P. Yeung	9/18/2024
_____ Reviewer Name	_____ Date Reviewed









Need help with an AndyMark product? Contact us at [support@andymark.com](mailto:support@andymark.com) or (877)-868-4770.

## Parts & Tools

### Recommended Tools List

Component	Part #	QTY	Photo
5/32" Ball End Hex Driver	am-2751	1	
2.5mm Hex Driver, L-Shaped	am-1288	1	
3/8 Combination Wrench	am-4961	1	

### Parts List

Component	Part #	QTY	Photo
Cog Drive Servo Bracket	am-5041	1	
0.5" 10-32 Socket Head Cap Screw	am-1002	2	
1" 10-32 Socket Head Cap Screw	am-1056	2	
1.5" 10-32 Socket Head Cap Screw	am-1014	8	
10-32 Nylock Jam Nut	am-1063	12	
ROBITS 2x4 Plate Gusset	am-5006_2x4	4	
#10 Washer	am-1026	8	
5mm Unflanged Bearing	am-4724	8	



Component	Part #	QTY	Photo
ROBITS Bushing	am-5021	1	
7T Cog	am-5472	1	
1.25" 10-32 Socket Head Cap Screw	am-1041	2	
0.125" #10 Screw Spacer	am-1732	2	
ROBITS Motor Mount, 80T-100T	am-5017	1	
0.5" Shaft Spacer	am-1699	1	
8mm M3 Socket Head Cap Screw	am-1500	3	
1/4" #10 Nylon Screw Spacer	am-1700	6	

## Assembly

### Step 1

Insert [4] 1.5" 10-32 Screws (am-1014) through the ROBITS 2x4 Plate Gusset (am-5006\_2x4) as shown.

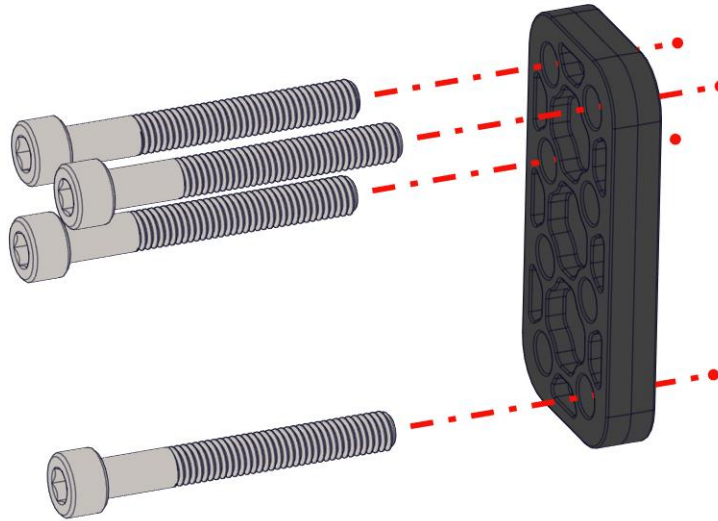

### Step 2

Slip a #10 washer (am-1026) over each of the top [2] screws as shown. Place a 5mm bearing (am-4724), a 1/4" screw spacer, and then a second 5mm bearing over the remaining screws as shown.

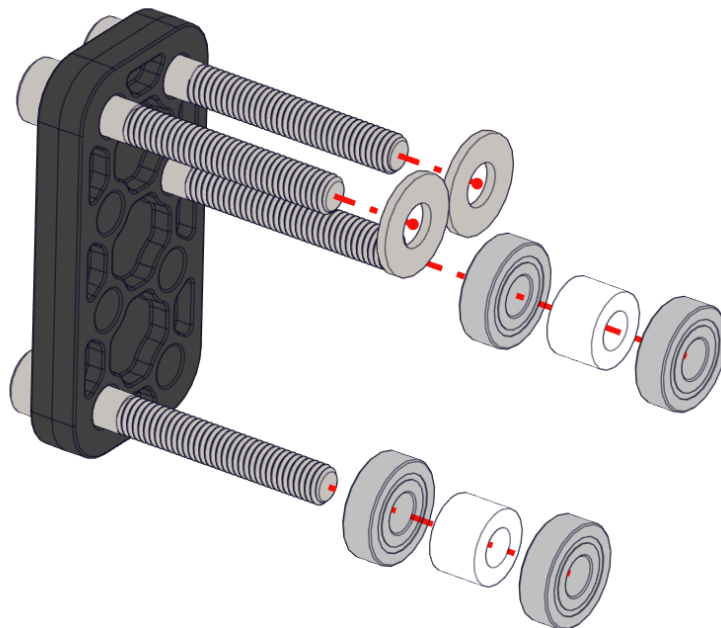

### Step 3

Slip a ROBITS tube (not included, am-5001-1400 shown) over both of the top screws, then slide [1] #10 washer (am-1026) over each screw as shown.

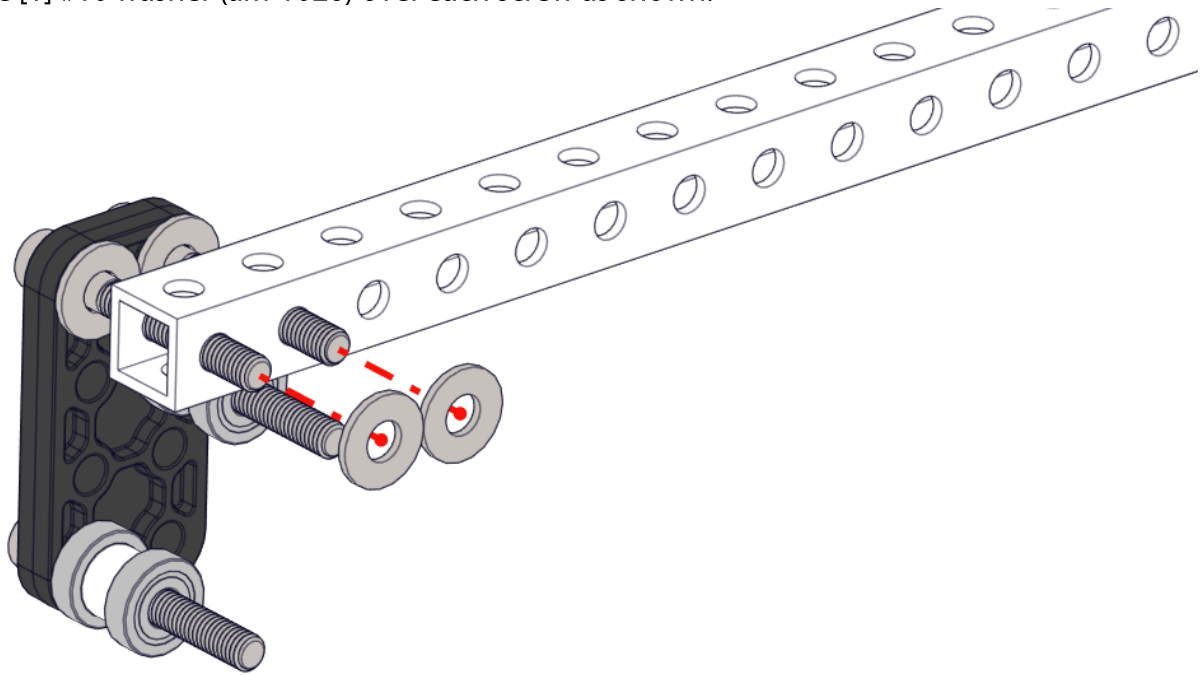

### Step 4

Cover the assembly with another ROBITS 2x4 Plate Gusset (am-5006\_2x4) and secure it in place using [4] 10-32 Nylock nuts, [1] for each screw. **Do not overtighten! A 0.5x0.5 ROBITS tube should be able to slide smoothly through the pocket in the assembly.**

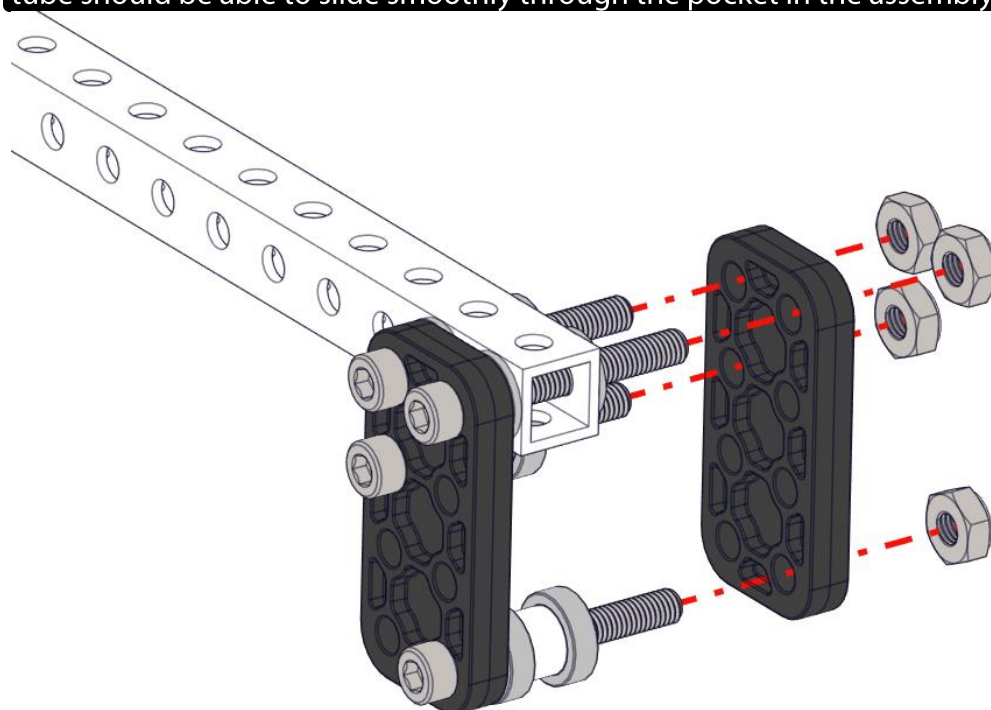

Step 5

Repeat Steps 1 through 4 to create a second assembly identical to the first.

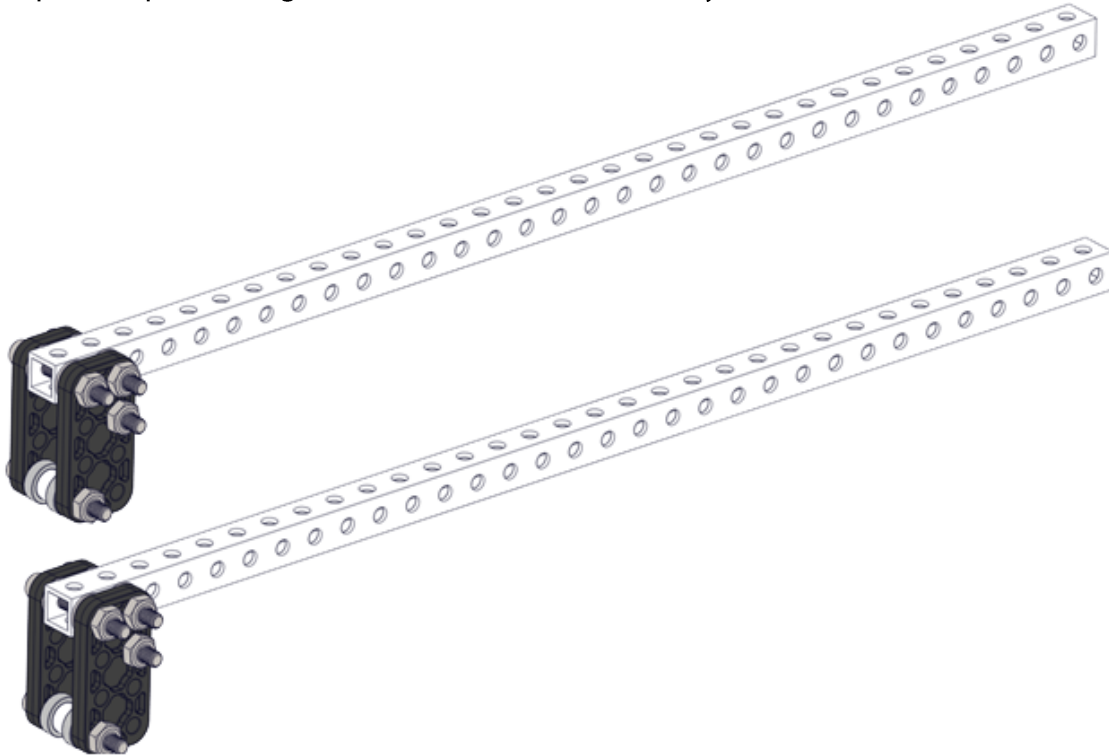

Step 6

Rotate one assembly and insert the two into each other as shown. Ensure the assemblies freely glide through each other when completely assembled.

**If the assemblies do not move freely, loosen the screws constraining the bearings until the tube movement is smooth. Retighten them until the screw can no longer slide axially.**

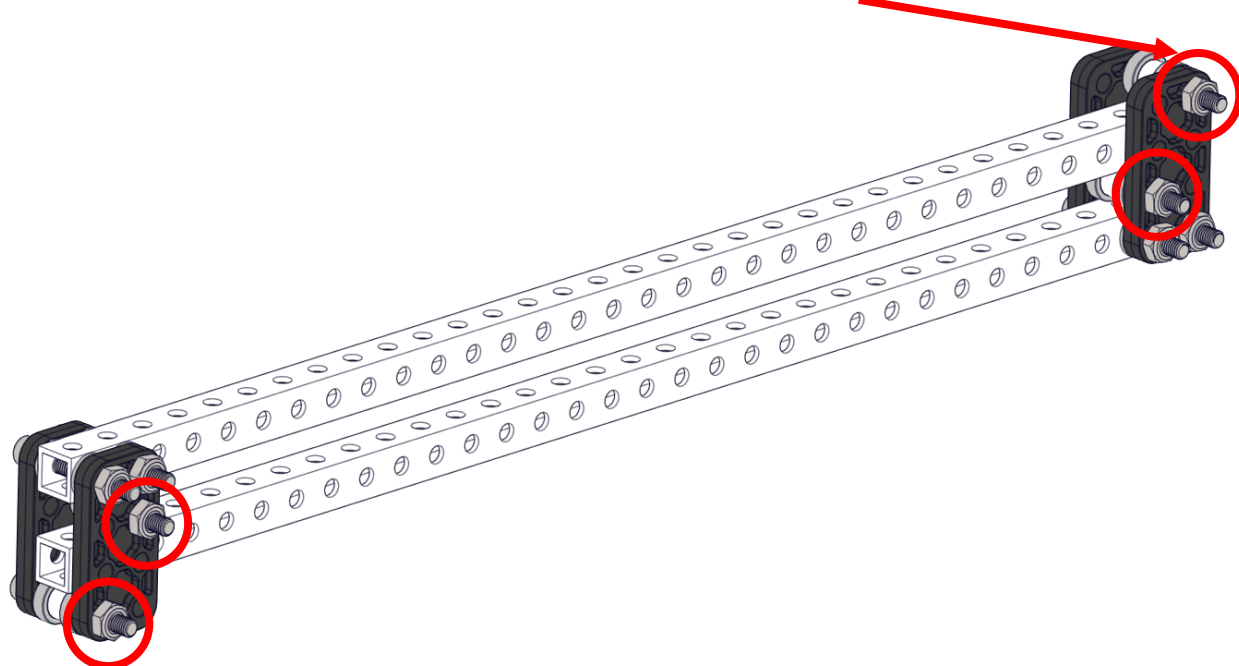



If you'd like to use a NeveRest motor to power your Cog drive, jump to Step 11. Otherwise, continue with Step 7.

Step 7

Attach a Cog Drive Servo Bracket (am-5041) to one of the assemblies using [2] 1" 10-32 Screws (am-1056) and [2] #10 Nylock Nuts (am-1063) where shown.

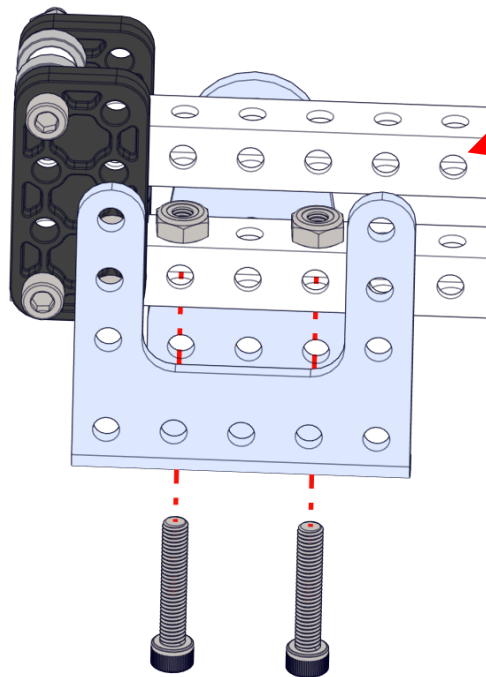

This assembly can be briefly pulled out to provide easier access during this step.

Step 8

Secure a Servo Adapter to a Servo using [1] M3 screw included with the adapter.

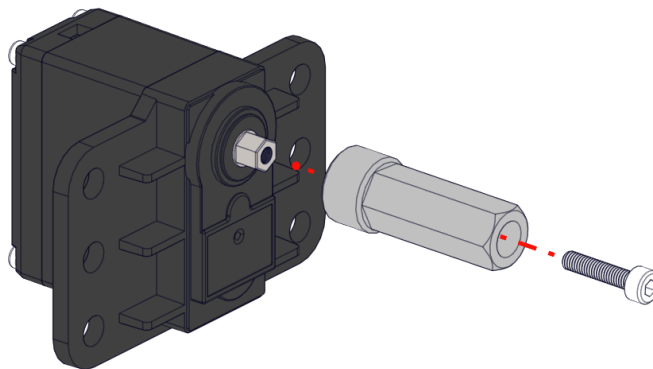



### Step 9

Place the 7 Tooth Cog (am-5472) so that its teeth insert into the holes on one of the assemblies. Insert the Servo through it, then secure the servo in place with [2] 0.5" 10-32 screws (am-1002) and [2] 10-32 nuts (am-1063). You may need to repeat this step to align the system properly with the servo's operating range.

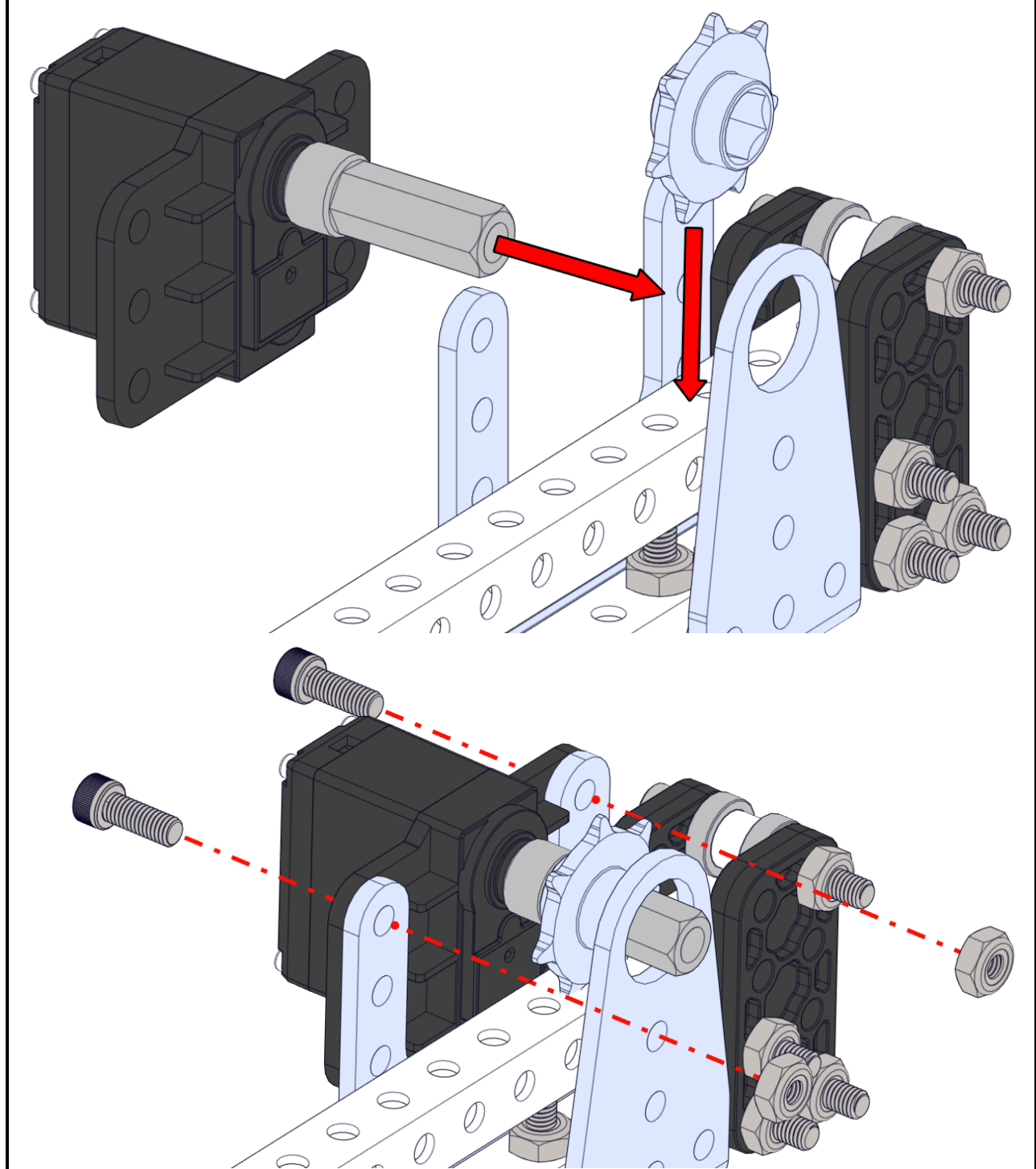

### Step 10

Slip a 0.5" Shaft Spacer (am-1699) over the end of the Servo shaft and secure it in place with the 1/4" washer and screw included with the Servo adapter. The servo-driven Cog Drive is now COMPLETE. Do not continue to Step 11.

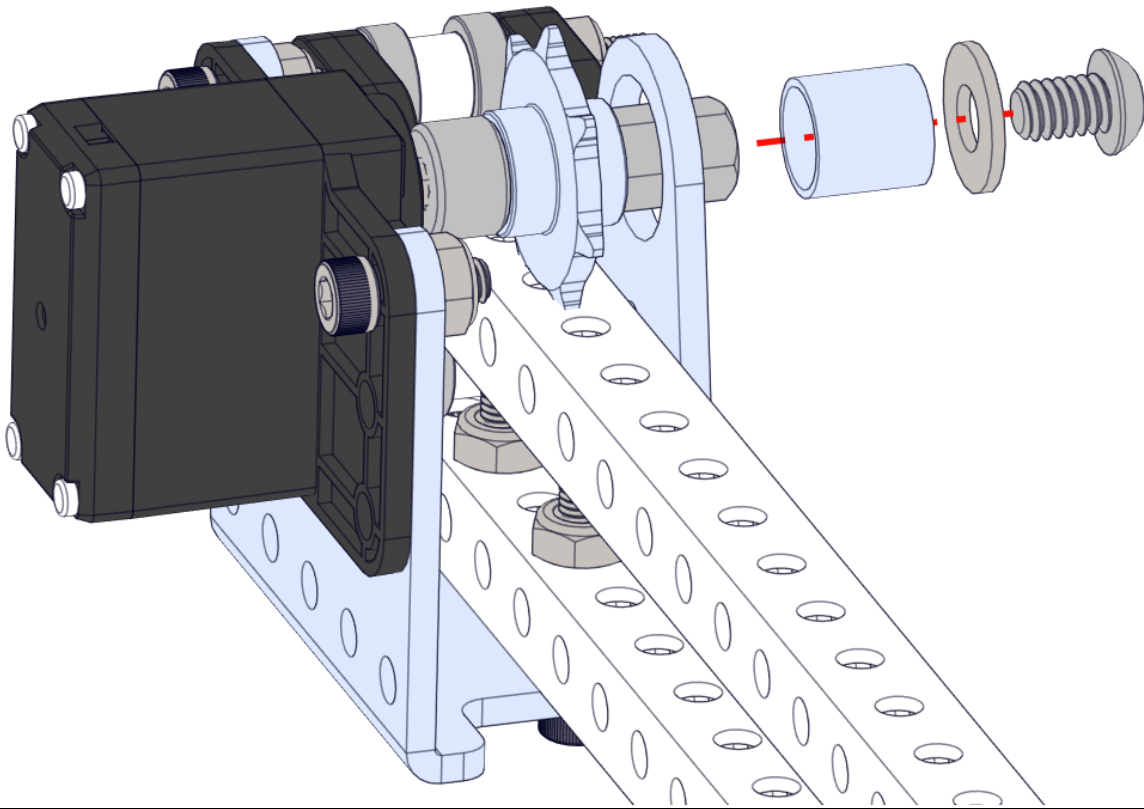

### Step 11

Attach the NeveRest to 3/8" hex adapter by slipping it over the shaft and tightening the set screw as shown.

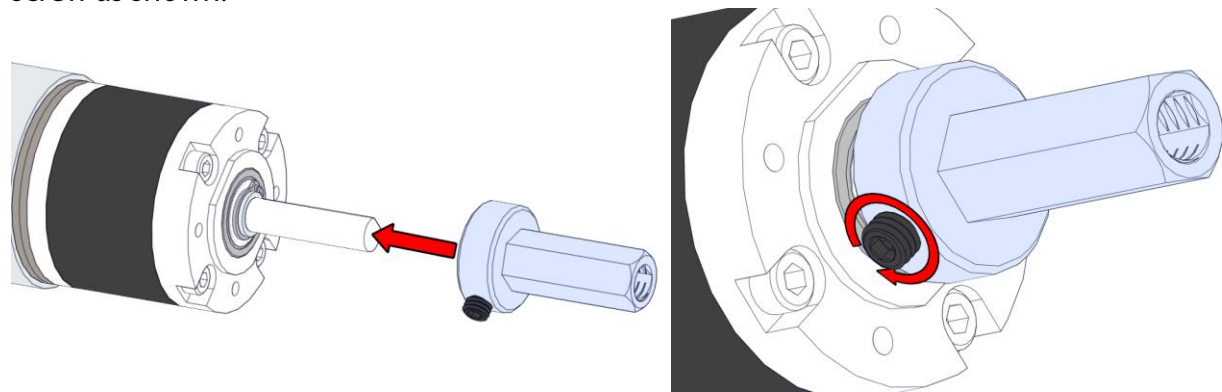

**Step 12**

Attach the NeveRest motor to a ROBITS Motor Mount, 80T-100T (am-5017) using [3] 8mm M3 screws (am-1500)

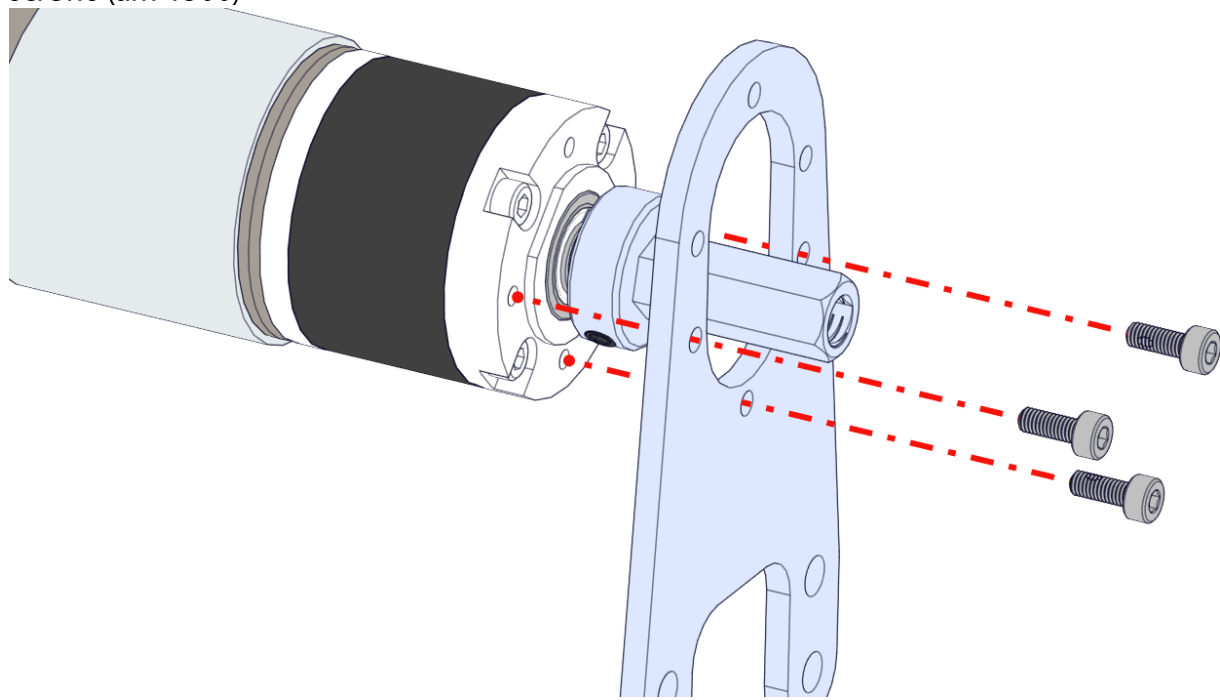

**Step 13**

With the 7 Tooth Cog (am-5472) ready in place through the holes in one of the ROBITS tubes, attach the motor/motor mount with [2] 1.25" 10-32 screws and [2] 10-32 nuts. Use [1] 0.25" Screw Spacer and [1] 0.125" Screw Spacer per screw to space motor off the ROBITS tube it is being mounted to.

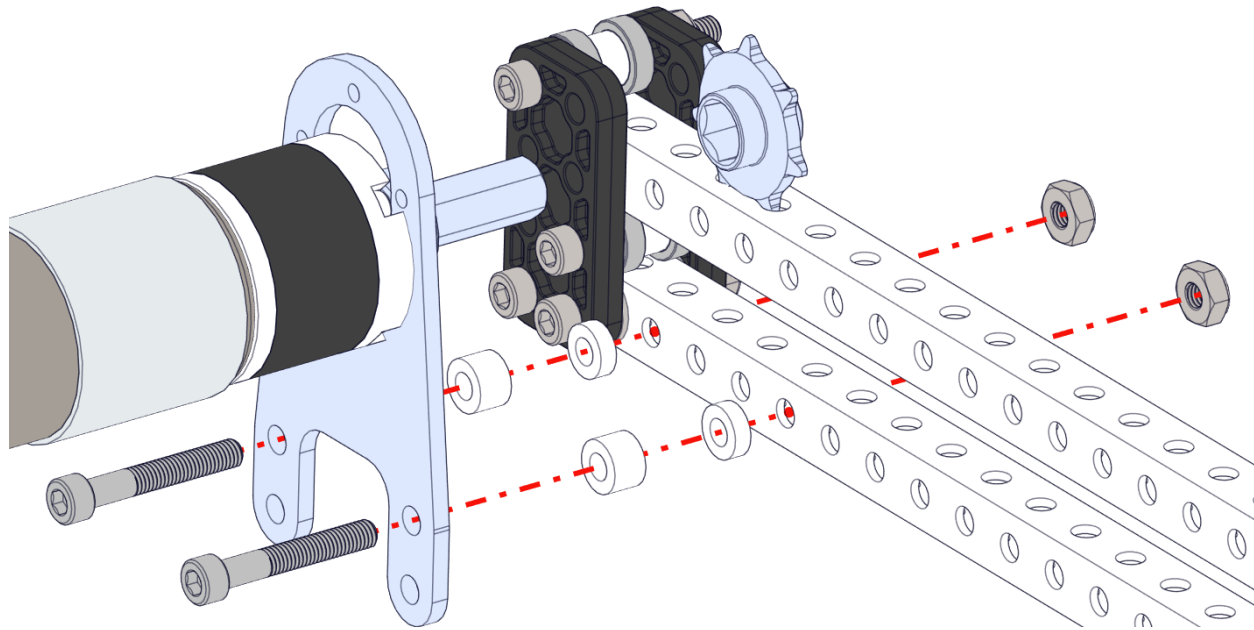

**Step 14**

Slip a 0.5" Shaft Spacer (am-1699) over the end of the Servo shaft and secure it in place with the 1/4" washer and screw included with the shaft adapter. The motor-driven Cog Drive is now COMPLETE.

