

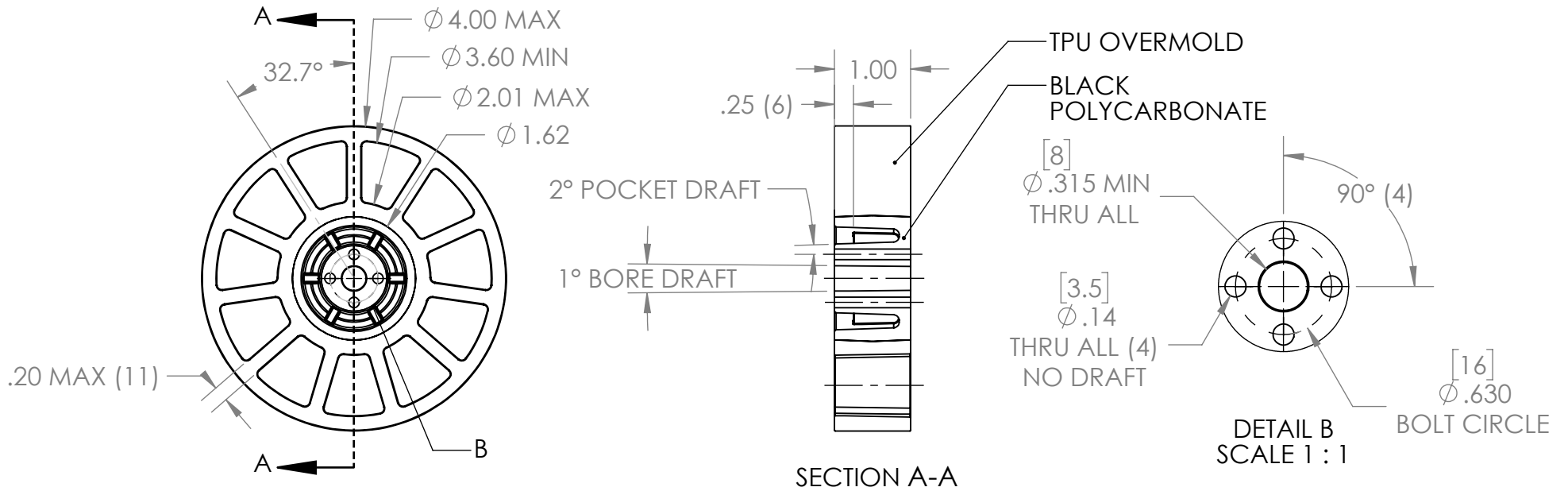

REVISION HISTORY			
REV.	DESCRIPTION	DATE	DRAWN BY
1	ORIGINAL PRINT	5/15/2017	J. ANG
2	UPDATED TO AMDS-1	5/14/2018	A. MILLS
3	REMOVED DUROMETER TABLE, ADDED ISO VIEW	9/4/2019	N. LAWRENCE
4	UPDATED DIMS	10/29/2019	K. KOLODZIEJ
5	UPDATE TO NOTE DRAFTS	9/19/2024	P. YEUNG

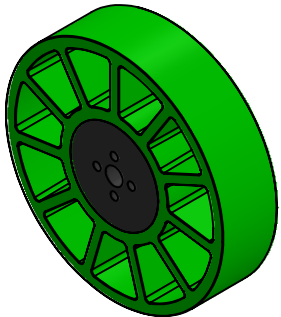

*** SEE CAD FOR ADDITIONAL TOOLPATH INFO***



UNLESS OTHERWISE SPECIFIED:		COMMENTS:				
DIMENSIONS ARE IN INCHES		DUAL DIMENSIONS ARE IN MILLIMETERS.		TITLE:		
TOLERANCES: FRACTIONAL $\pm 1/16$ ANGULAR: MACH $\pm 1^\circ$ ANGULAR: BEND $\pm 5^\circ$ ONE PLACE DECIMAL ± 0.1 TWO PLACE DECIMAL ± 0.01 THREE PLACE DECIMAL ± 0.005 FOUR PLACE DECIMAL ± 0.0005		BREAK ALL SHARP EDGES		4IN NUB BORE COMPLIANT WHEEL		
MATERIAL PC CORE		2° DRAFT ON MOST SURFACES UNLESS OTHERWISE NOTED.		SIZE	DWG. NO.	REV
TPU OVERMOLD		CHECKED	NAME	A	am-3563	5
FINISH DEBURRED		ENG APPR.	DATE			
DO NOT SCALE DRAWING		MFG APPR.	9/20/24			
		Q.A.		SCALE: 1:2	WEIGHT:	SHEET 1 OF 1