

Robits 1 Stage Lift Assembly Guide

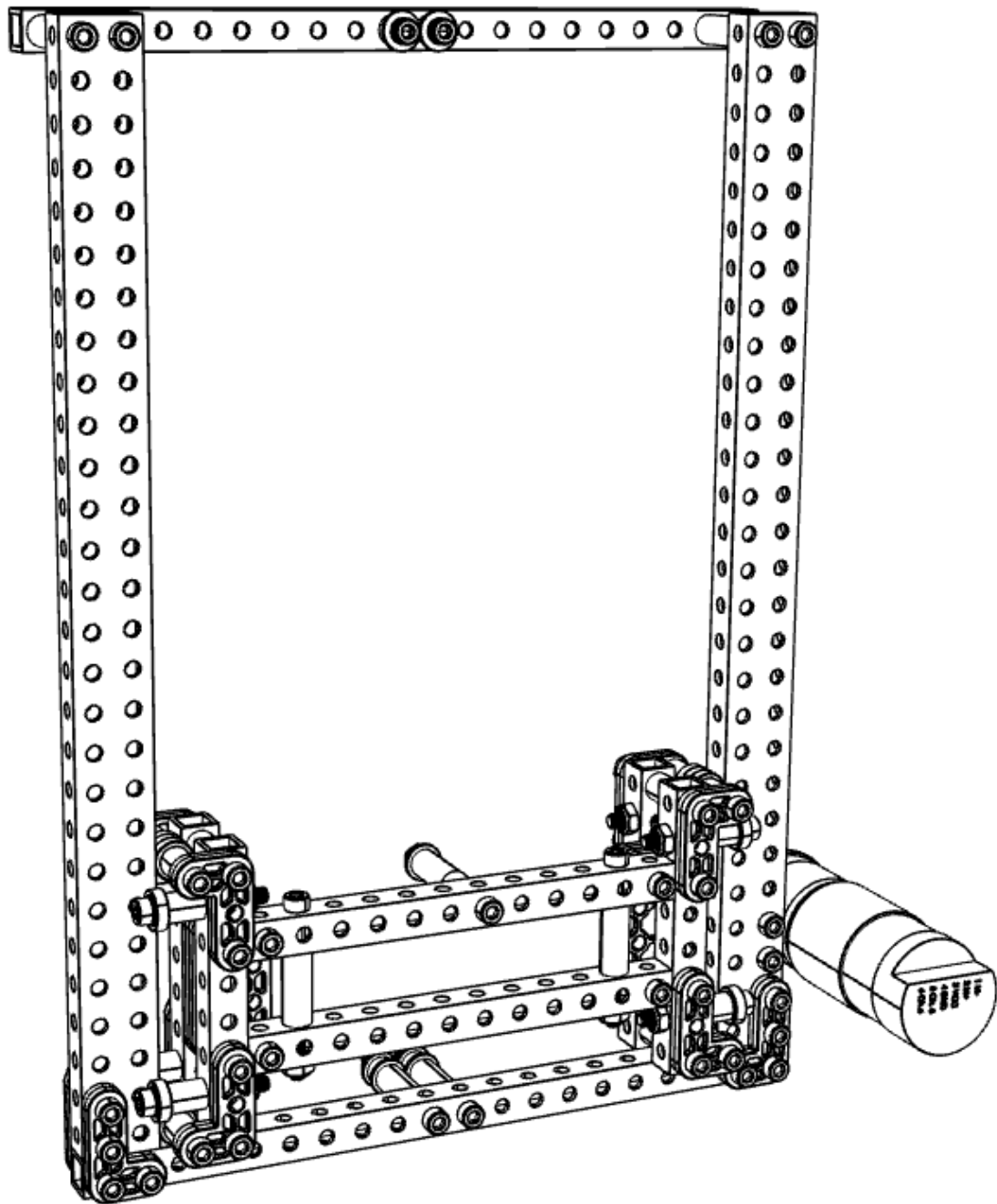

Carriage Assembly

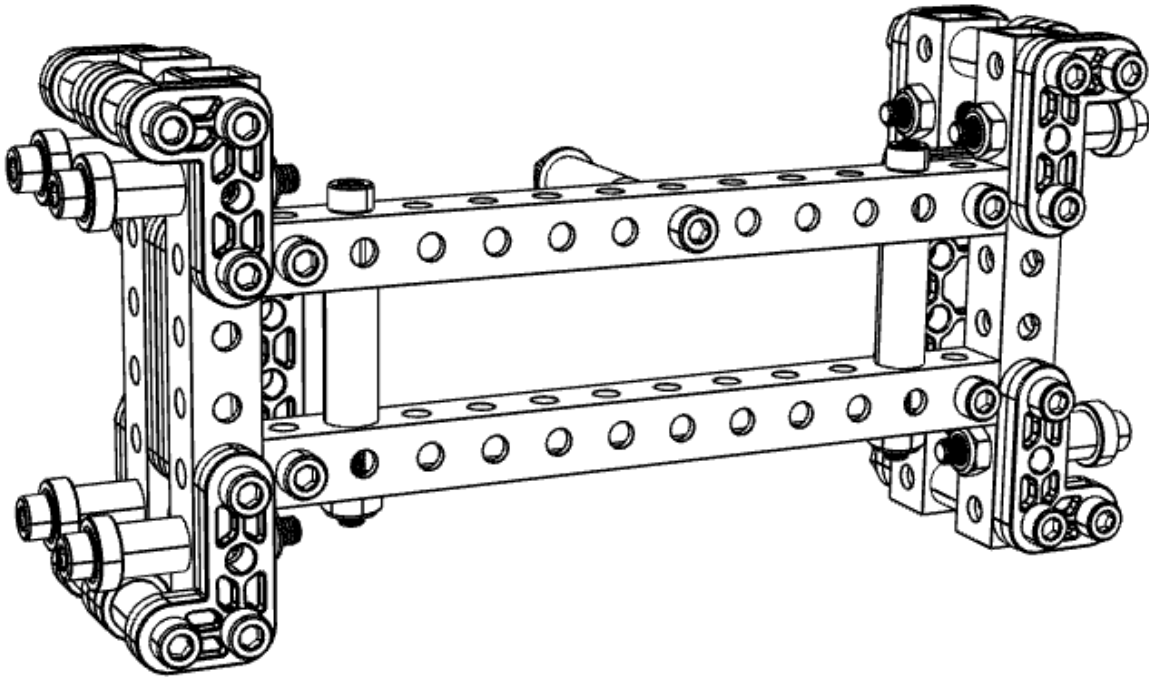

Install two 1 inch spacers (am-1696) between two 0.5 x 0.5 x 6.0 inch tubes (am-5001-0600) using two 10-32 x 2250 screws (am-1156) and two 10-32 Nylock nuts (am-1063).

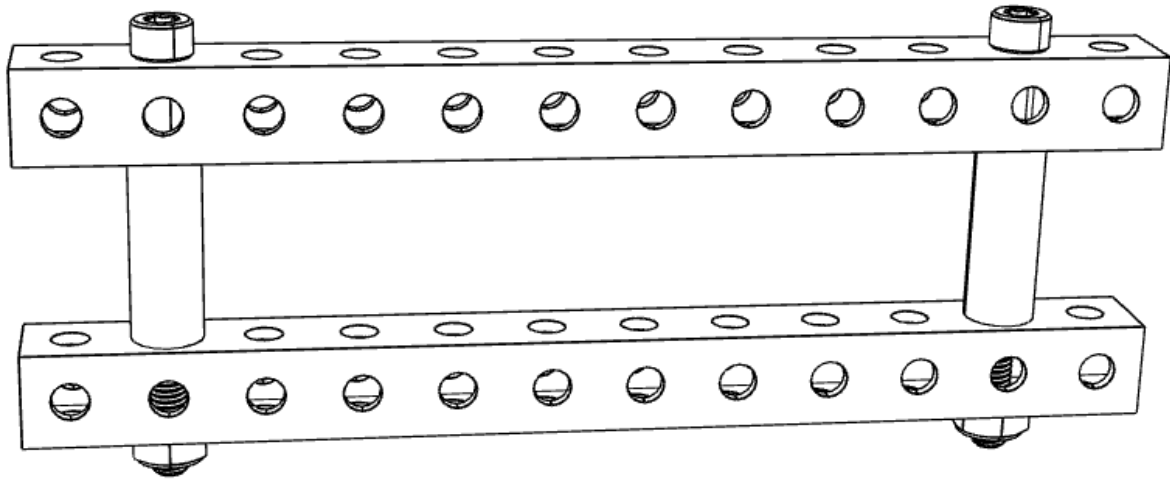

Fasten two 2 x 4 plates (am-5006_2x4) with two 10-32 x 1250 screws (am-1041) and two 10-32 Nylock nuts (am-1063) to each side.

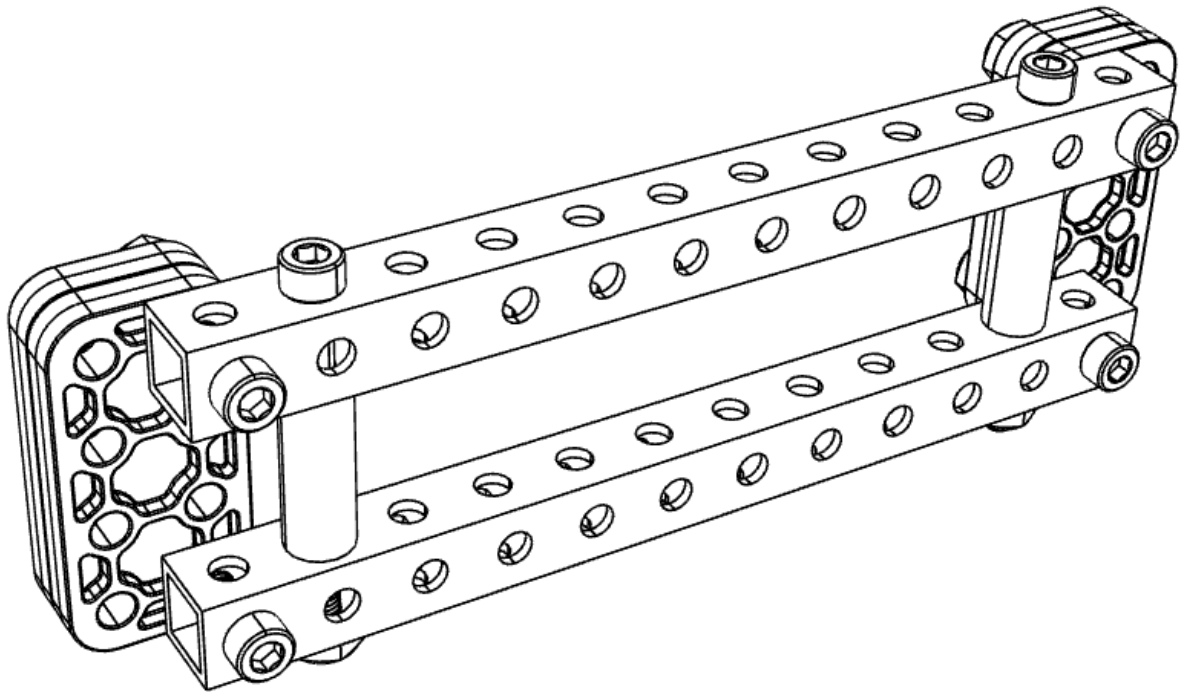

Install two bearings (am-4724) and two ½ inch screw spacers (am-1697) to a 0.5 x 0.5 x 4.0 tube (am-5001-0400) with two 10-32 x 1500 screws and two 10-32 Nylock nuts. Repeat this process to create two bearing assemblies.

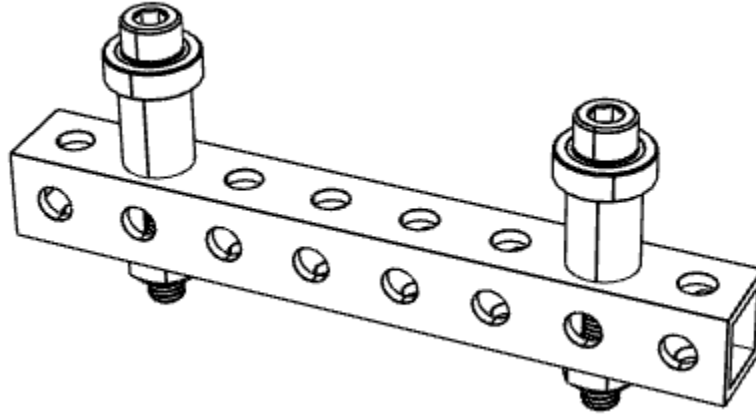

Fasten both bearing assemblies to the 2 x 4 plates using the following stackups.

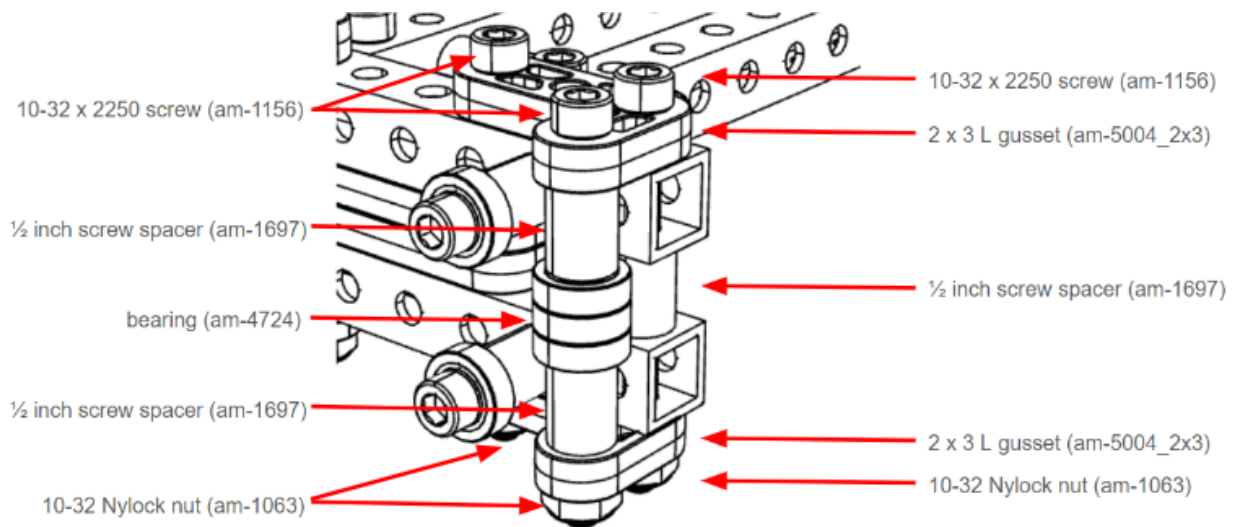

Repeat on the opposite side.

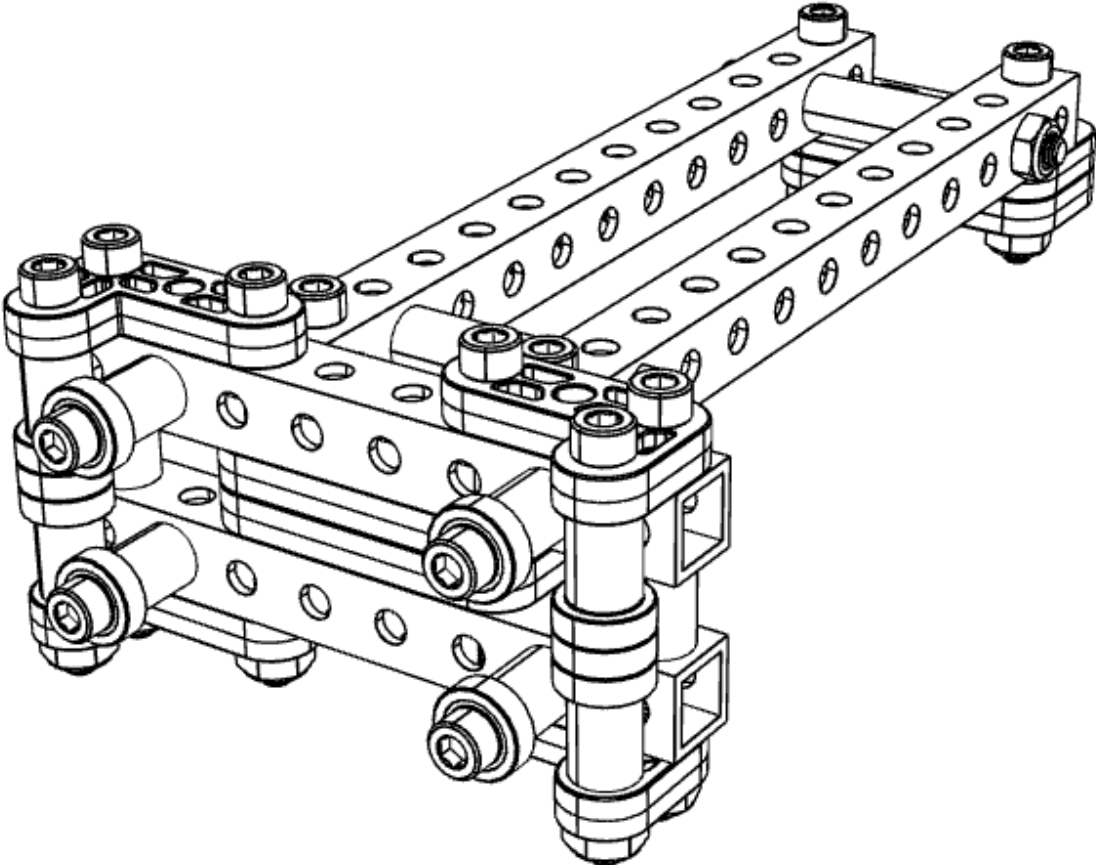

Repeat on the opposite side.

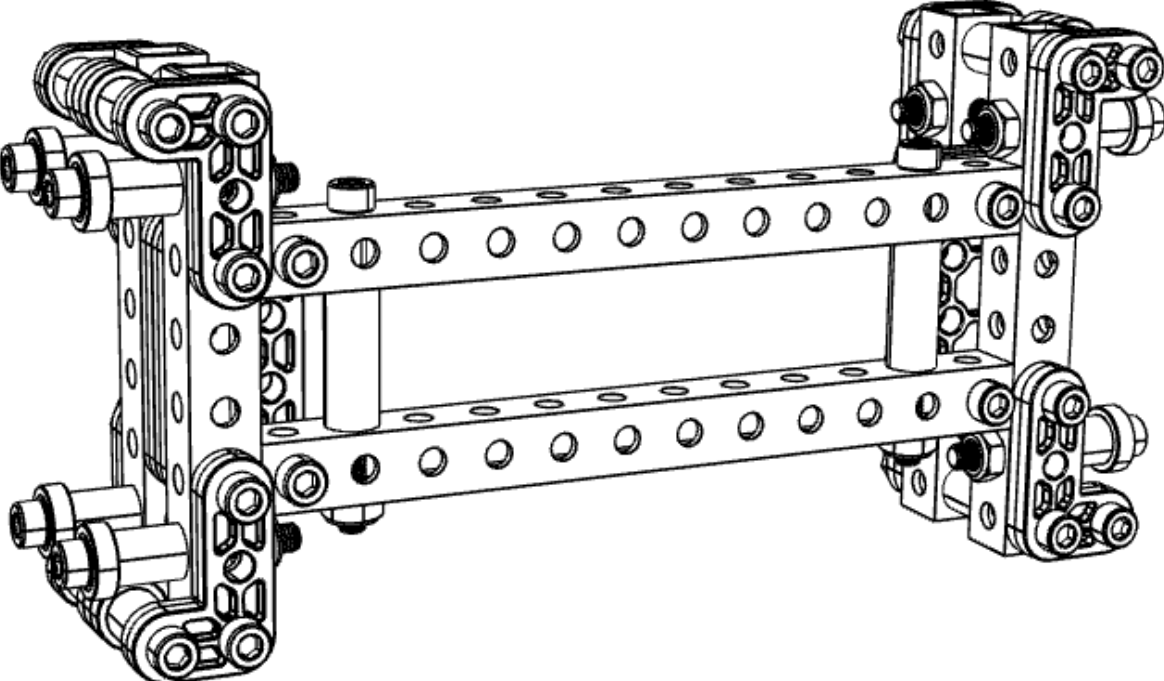

Install one ½ inch screw spacer (am-1697) and one 1 inch screw spacer (am-1696) using a 10-32 x 2250 screw (am-1156), #10 washer (am-1026), and a 10-32 Nylock nut (am-1063).

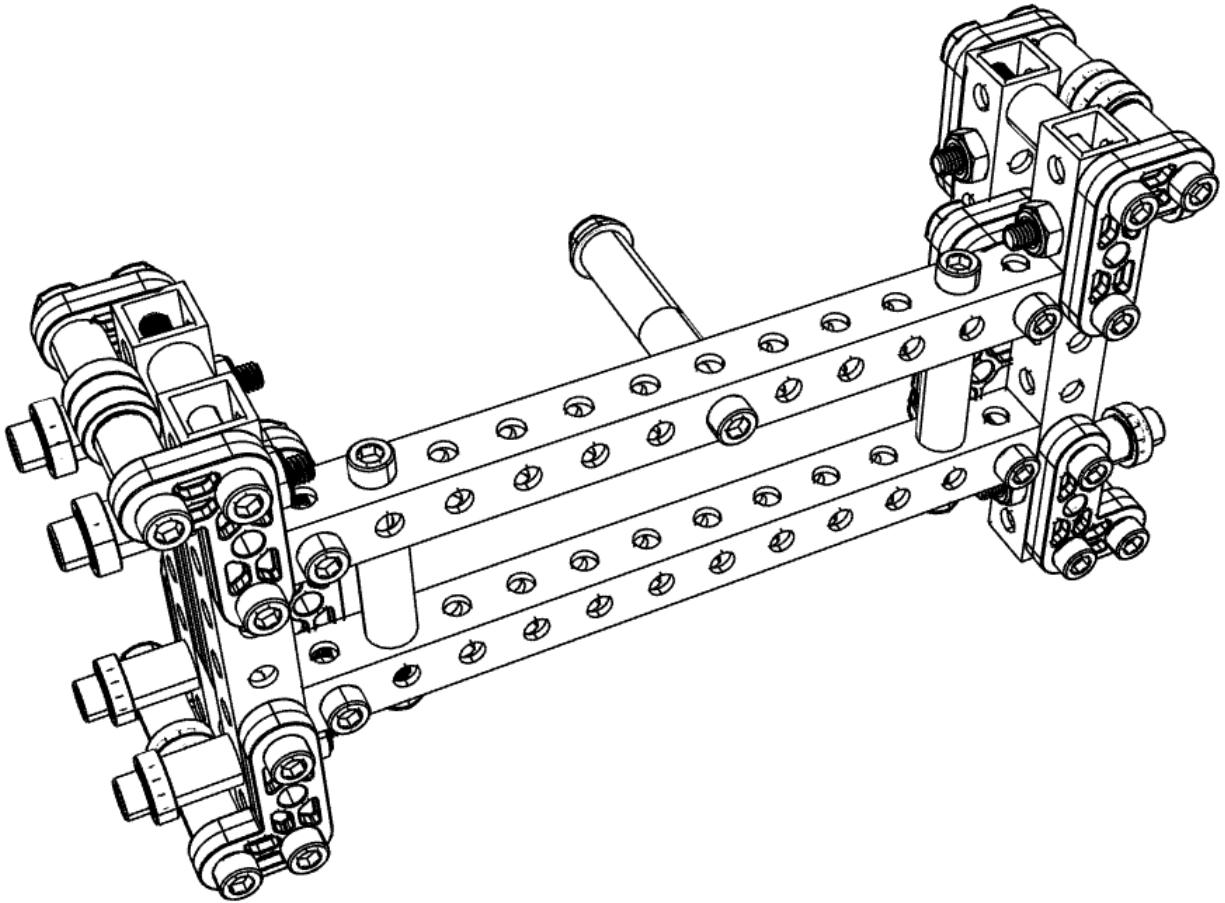

Frame Assembly

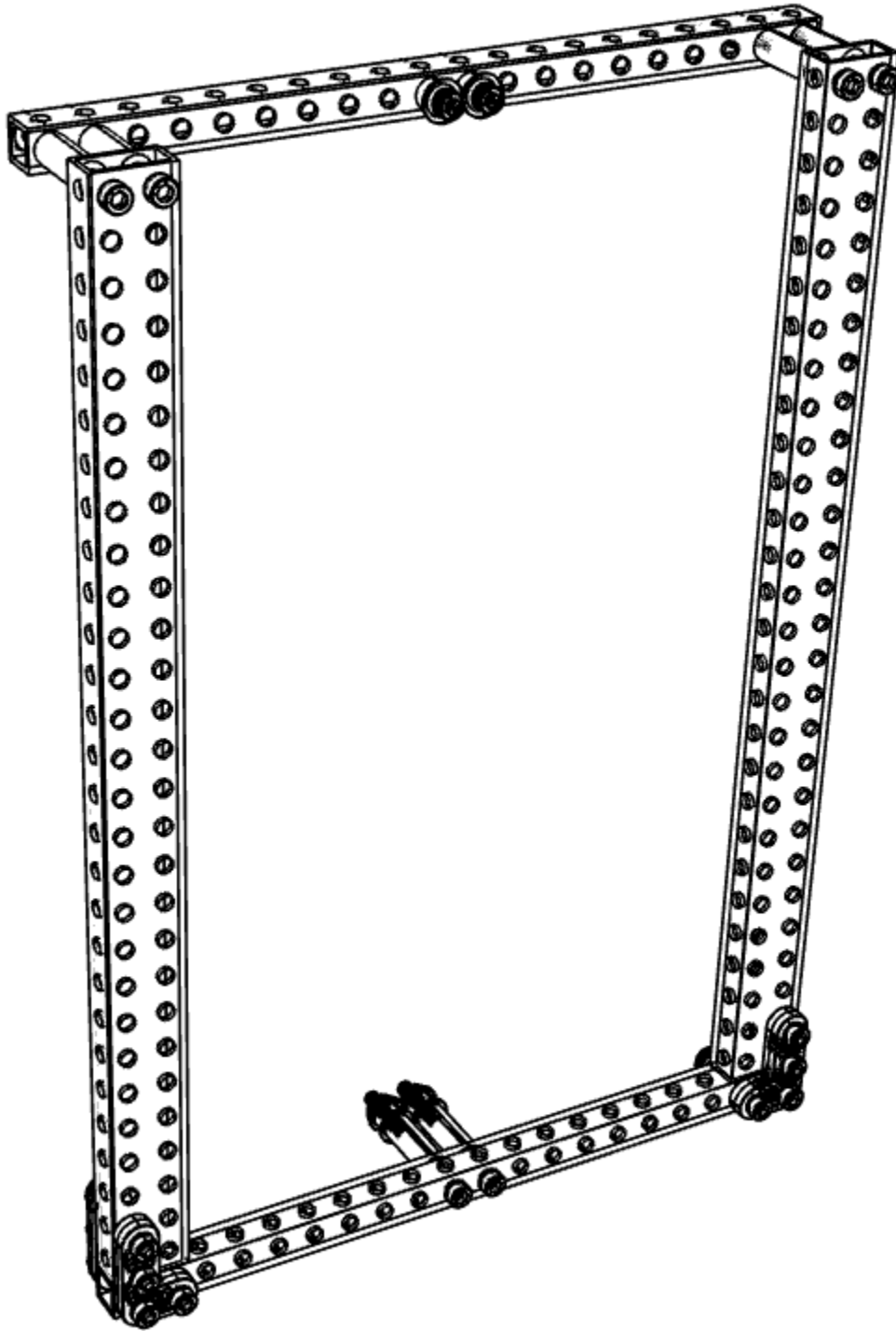

Install a total of four 2 x 3 L gussets (am-5004_2x3) to a 0.5 x 0.5 x 10.0 tube (am-5001-1000) using four 10-32 x 1250 screws (am-1041) and four 10-32 Nylock nuts (am-1063).

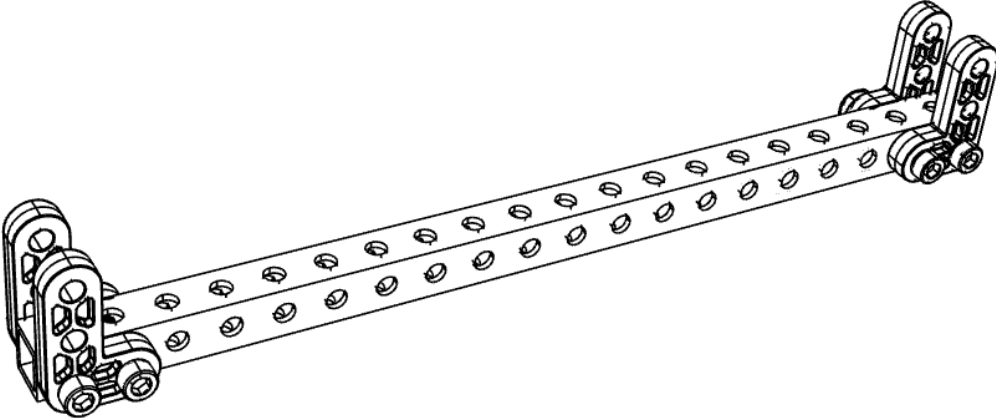

Install two 1.0 x 0.5 x 14.0 tubes (am-5026-1400) to the L gussets using four 10-32 x 1250 screws (am-1041) and four 10-32 Nylock nuts (am-1063).

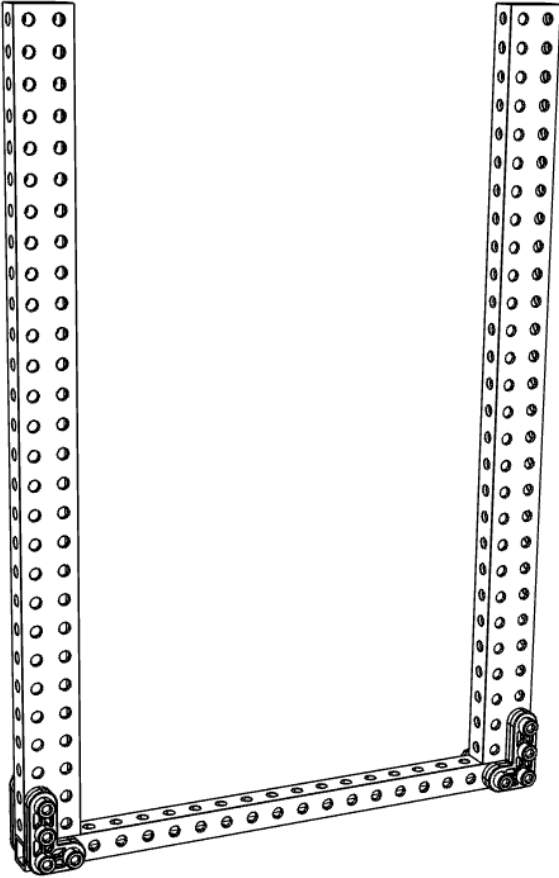

Install two ¼ inch screw spacers with a #10 washer on either side.

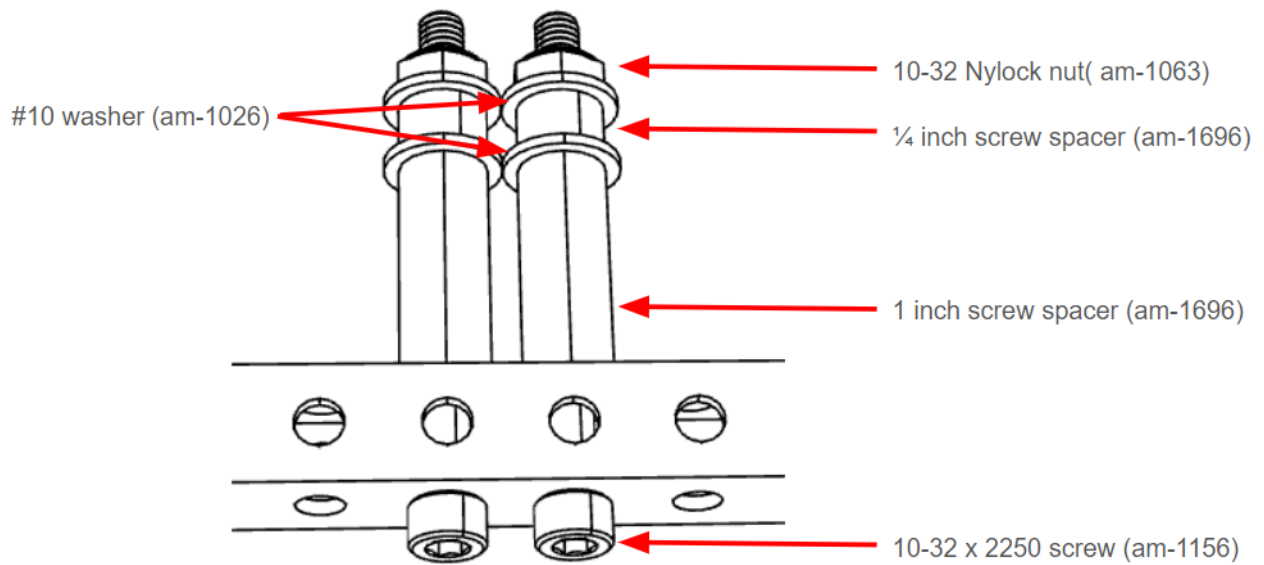
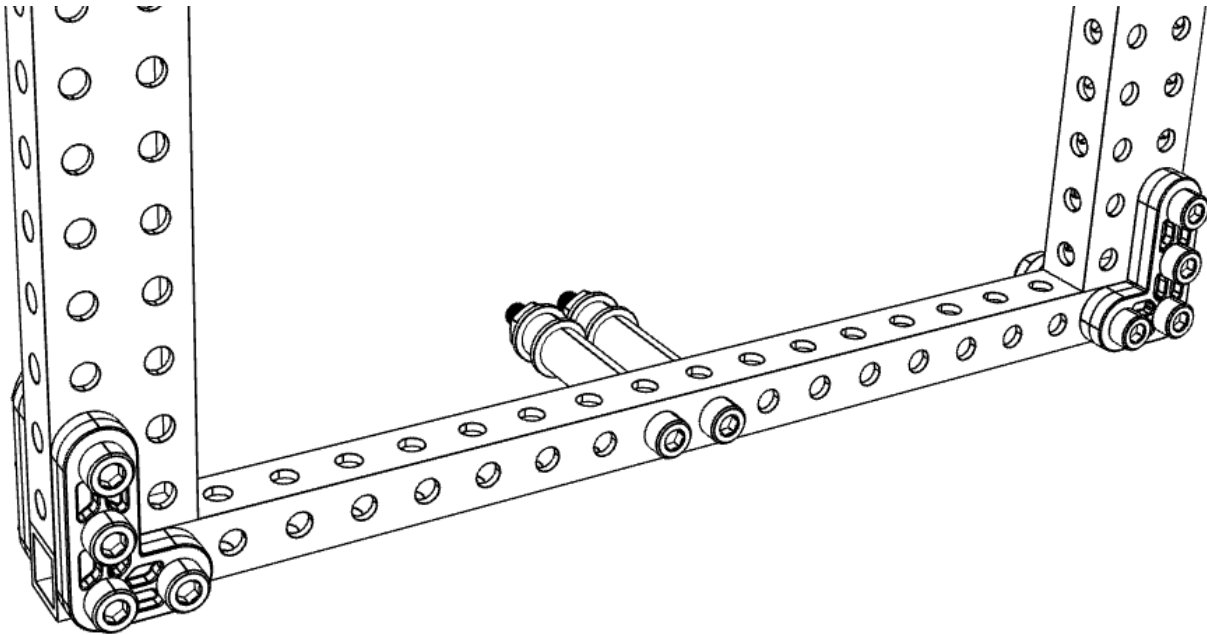

Insert carriage into frame assembly

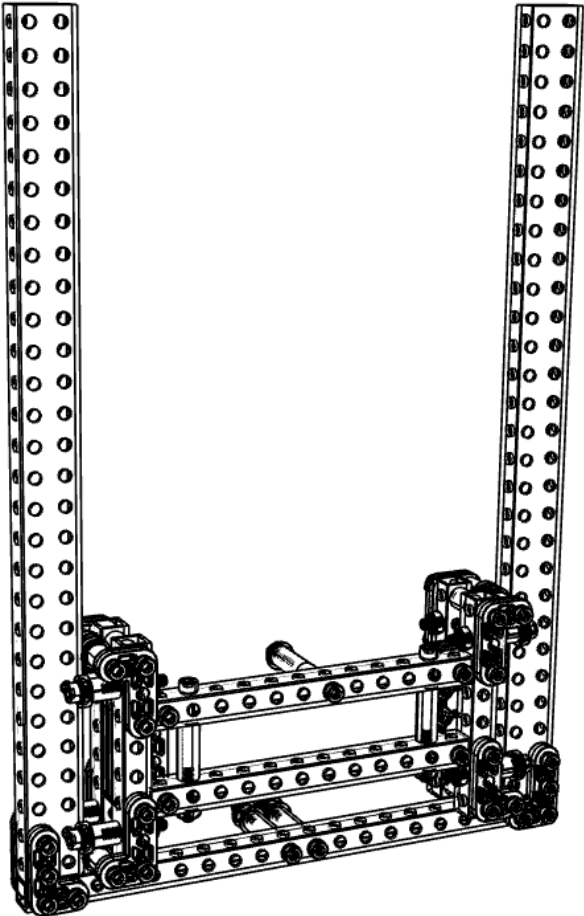

Fasten a 0.5 x 0.5 x 10.0 tube to the top of the frame using four 10-32 x 2250 screws (am-1156), four 1 inch screw spacers (am-1696), and four 10-32 Nylock nuts (am-1063)

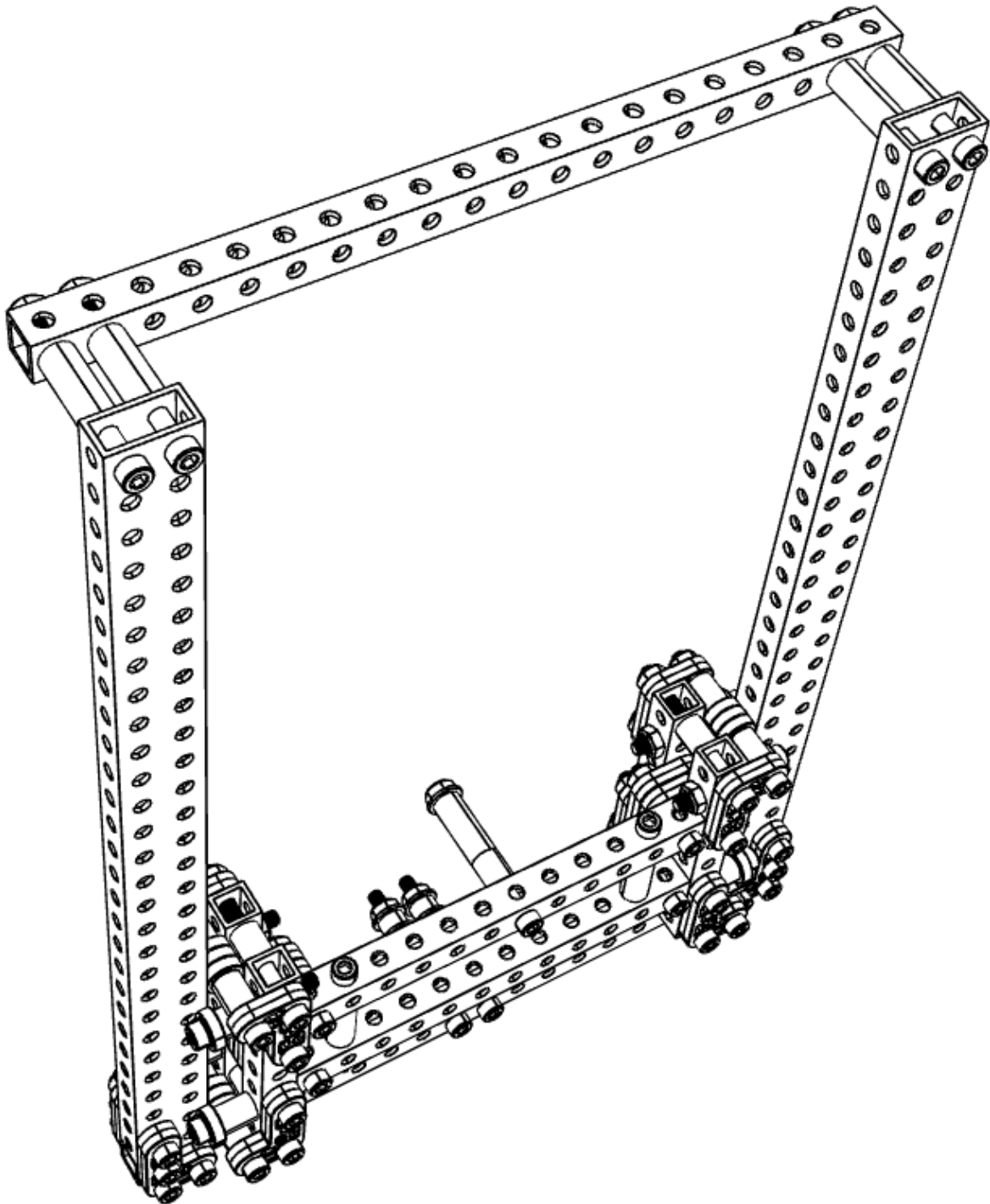

Install two ¼ screw spacers (am-1700) to the top of the frame using two 10-32 x 1000 screws (am-1056), two #10 washers (am-1026), and two 10-32 Nylock nuts (am-1063).

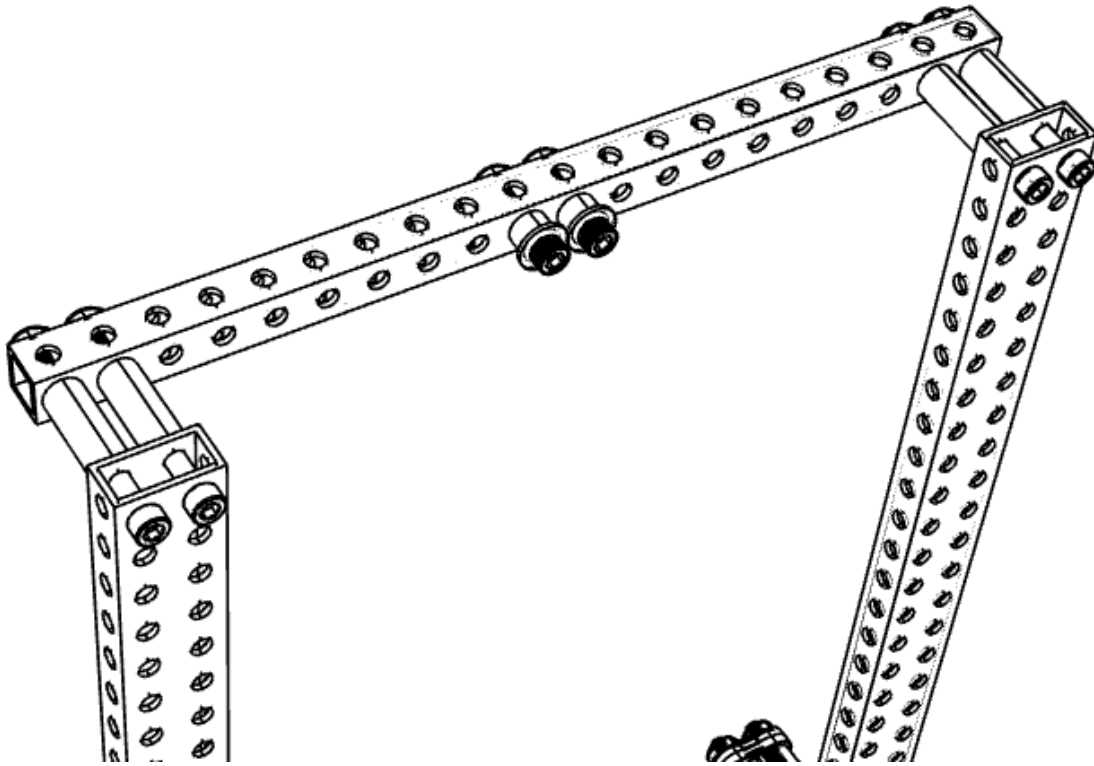

Install the motor bracket (am-5012) to the side of the frame using two 10-32 x 1750 screws, two ¼ inch screw spacers (am-4107), and two 10-32 Nylock nuts (am-1063).

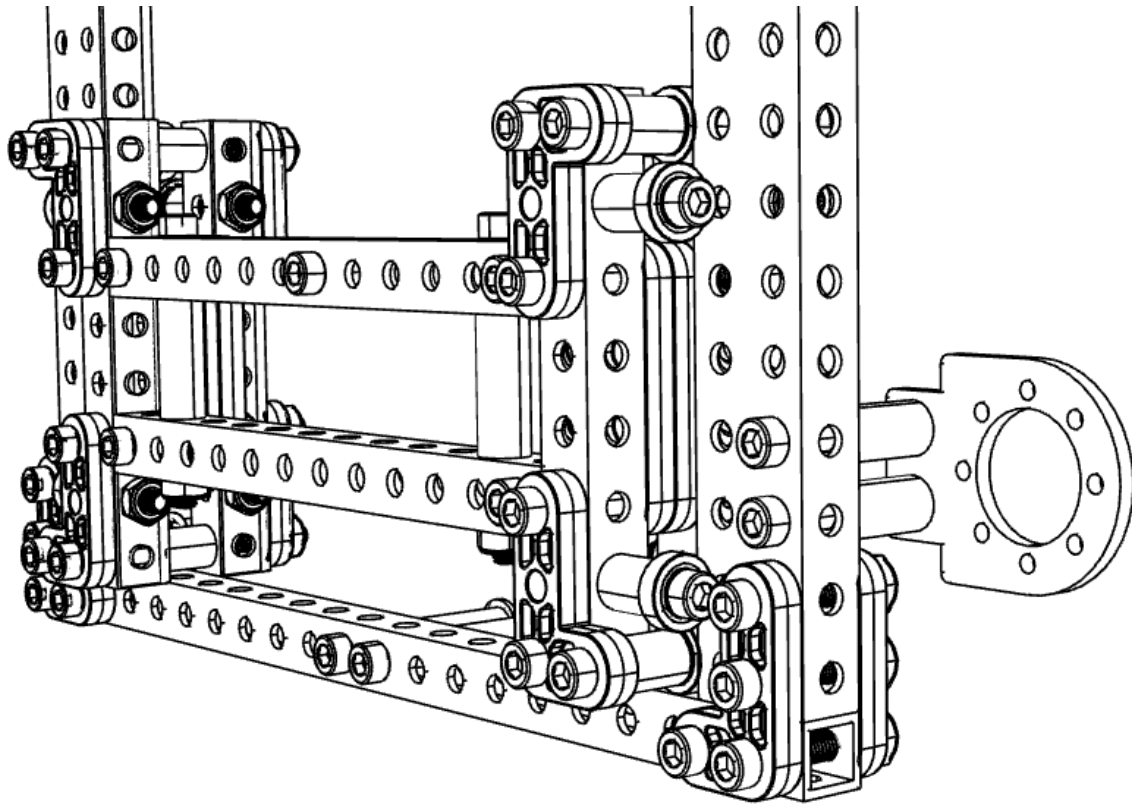

Place one 6mm to 375 Hex adapter (am-3444) on the motor shaft. Make sure to secure by tightening the provided 10-32 set screw.

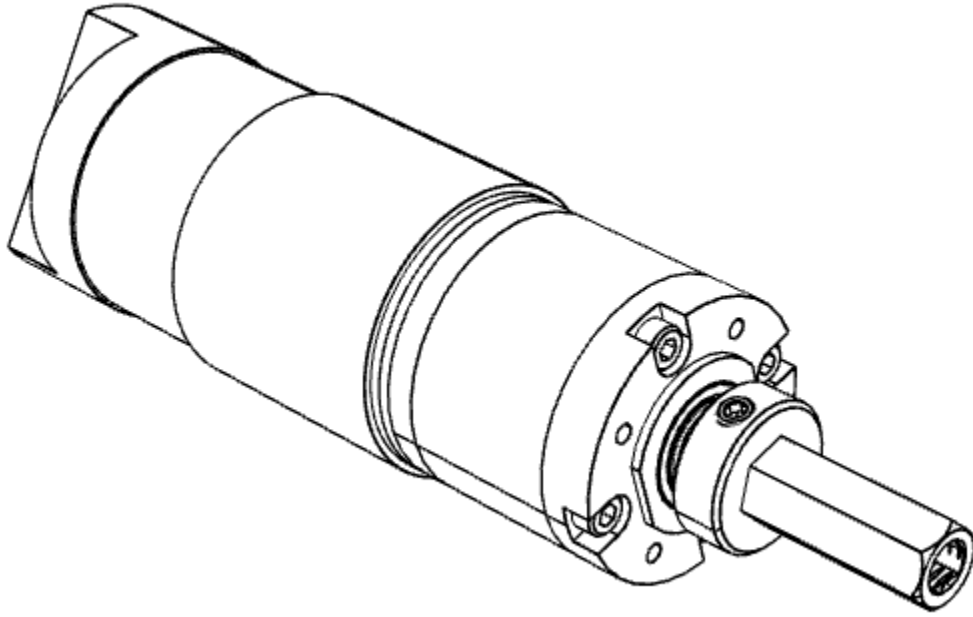

Install one NeveRest Orbital gearmotor to the motor mount plate using four M3-8mm patched screws (am-1500).

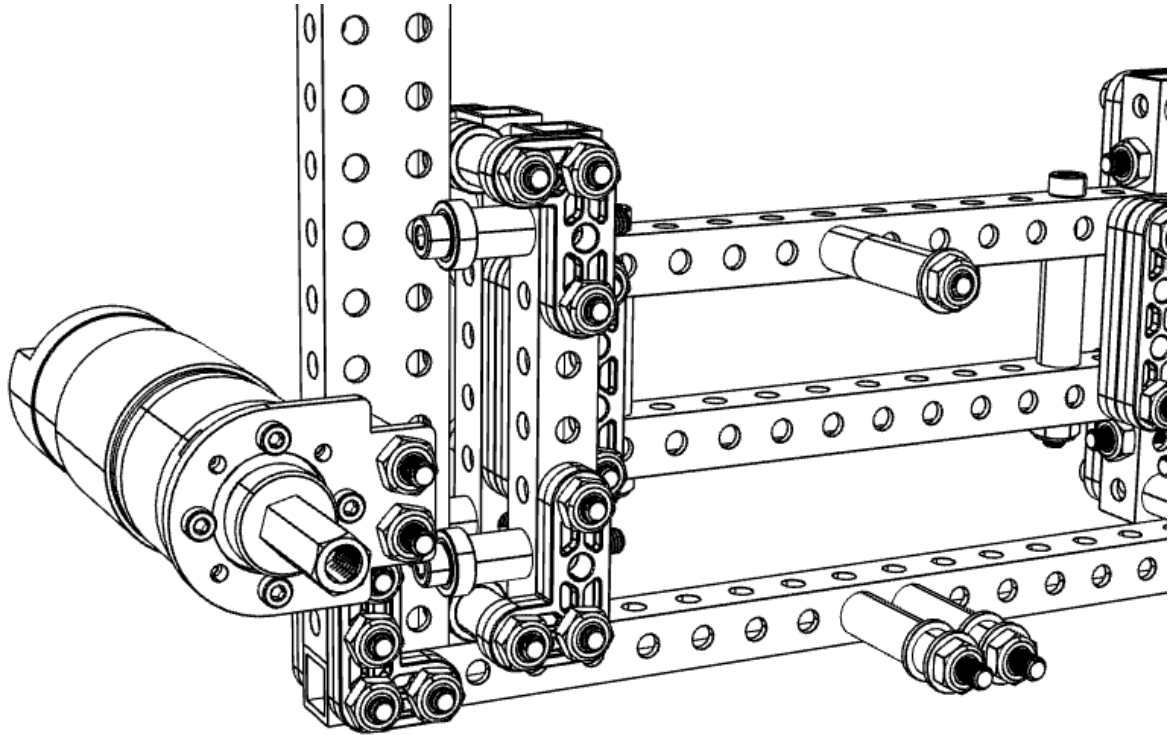

Install two spools (am-5027) onto the motor shaft and retain with the ¼ inch washer and screw provided with the adapter.

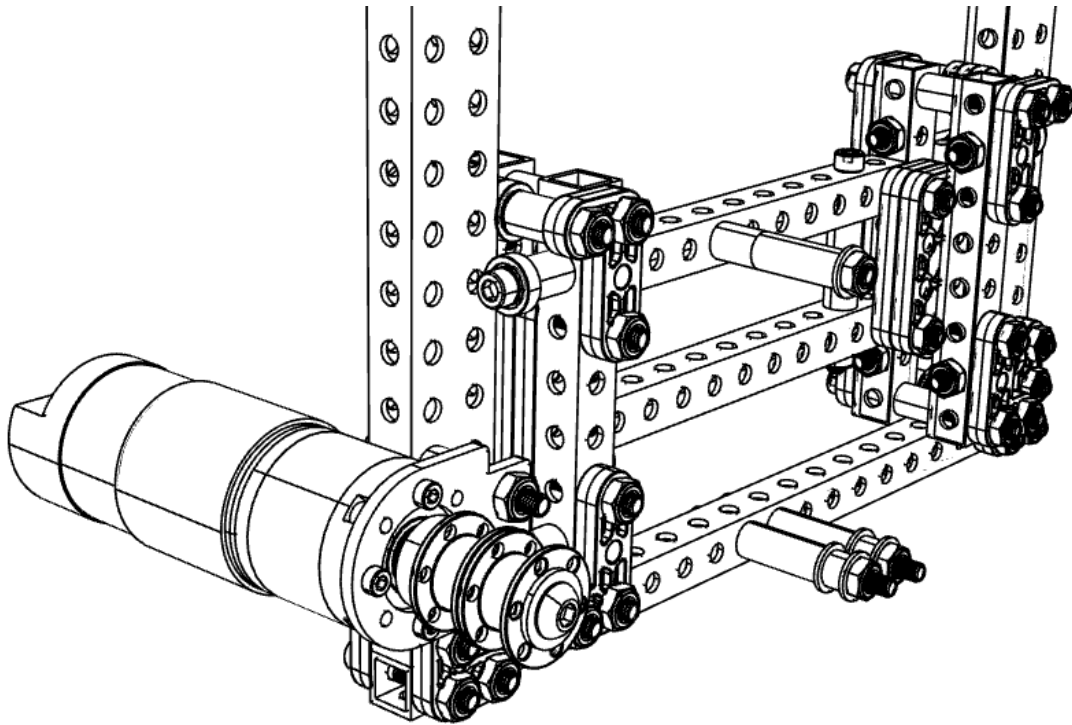

See stringing guide