

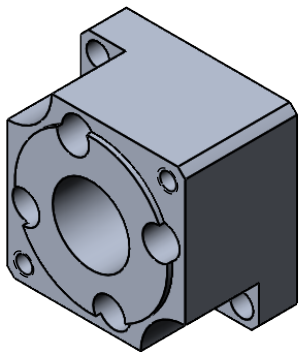

REVISION HISTORY			
REV.	DESCRIPTION	DATE	DRAWN BY
1	ORIGINAL PRINT	4/26/2024	N. MASSOUDA
2	REVISED CORNER FEATURES	7/15/2024	N. MASSOUDA
3	ADDED 1.375 BOLT CIRCLE	11/4/2024	N. MASSOUDA

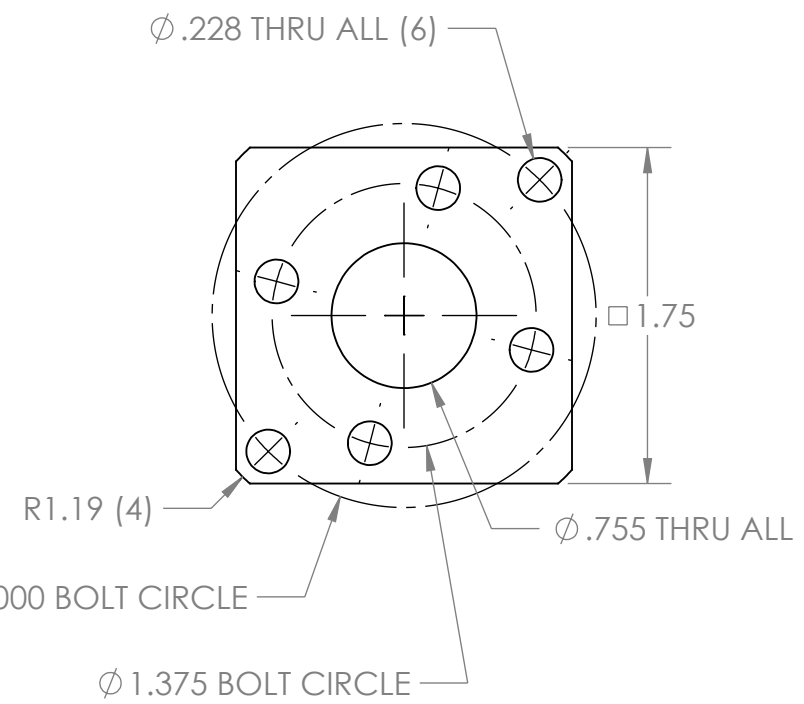
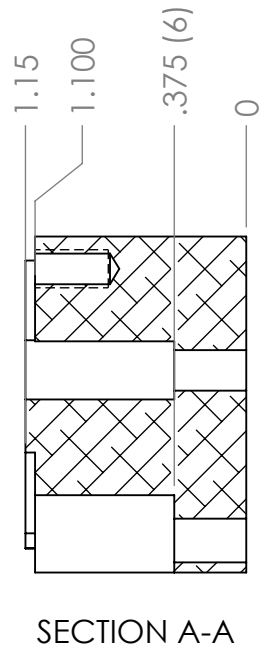
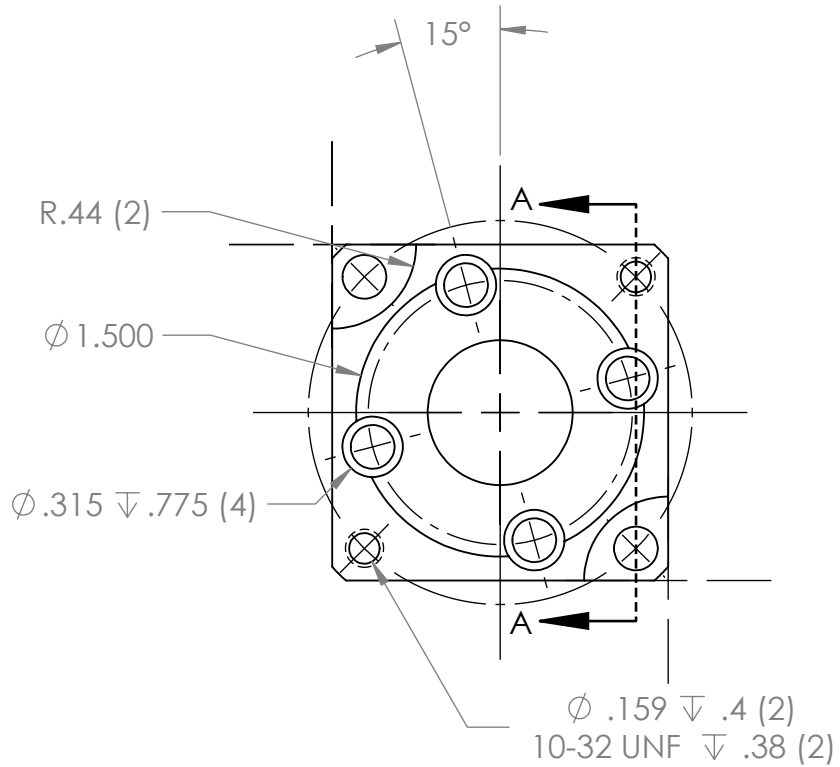

\*\*\* SEE CAD FOR ADDITIONAL TOOLPATH INFO\*\*\*

UNLESS OTHERWISE SPECIFIED:		COMMENTS:			
<b>DIMENSIONS ARE IN INCHES</b>		DUAL DIMENSIONS ARE IN MILLIMETERS.			
TOLERANCES:		BREAK ALL SHARP EDGES		TITLE:	
FRACTIONAL	±1/16			SPORT LONG SHAFT	
ANGULAR: MACH	±1°			MOTOR BLOCK	
ANGULAR: BEND	±5°			SIZE	
ONE PLACE DECIMAL	±0.1			DWG. NO.	
TWO PLACE DECIMAL	±0.01			A am-3770a	
THREE PLACE DECIMAL	±0.005			REV	
FOUR PLACE DECIMAL	±0.0005			3	
MATERIAL	6061-T6 AL	CHECKED	NAME	DATE	SCALE: 1:1
FINISH	DEBURRED	ENG APPR.	PY	11/4/24	WEIGHT:
DO NOT SCALE DRAWING		MFG APPR.			SHEET 1 OF 1
		Q.A.			