

4

3

2

1

REVISION HISTORY			
REV.	DESCRIPTION	DATE	DRAWN BY
1	ORIGINAL PRINT	6/25/2018	N. LAWRENCE

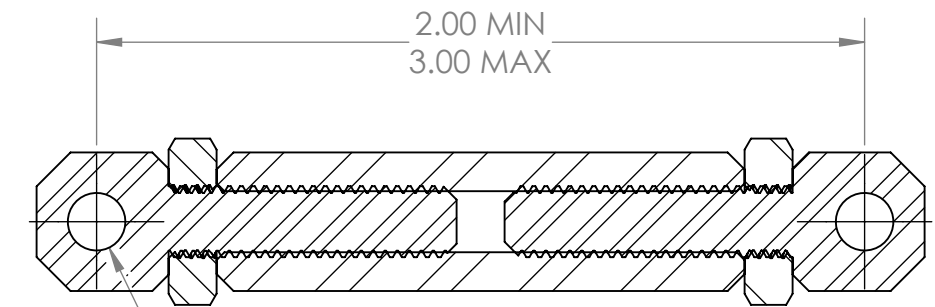
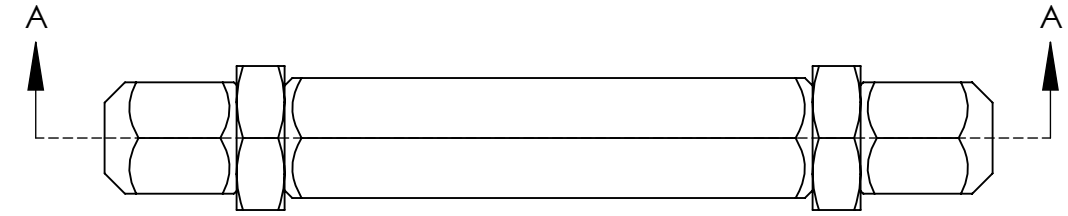
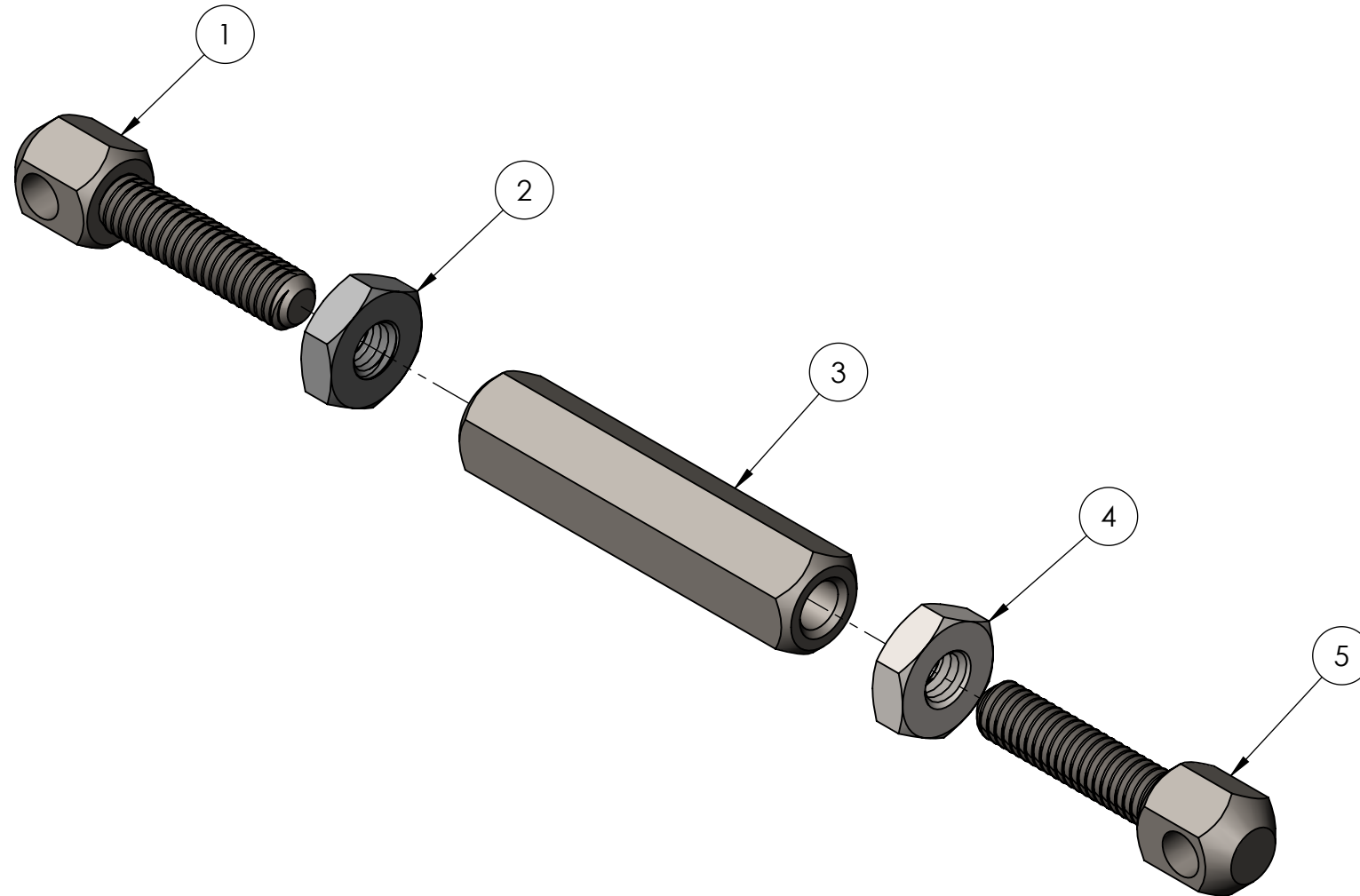

SECTION A-A
SCALE 2:1

$\phi .150$ THRU (2)

*** SEE CAD FOR ADDITIONAL TOOLPATH INFO***

BILL OF MATERIALS		
ITEM NO.	PART NUMBER	DESCRIPTION
1	am-3914_35_lhc	#35 CHAIN ATTACHMENT CLEVIS, LEFT HAND THREAD
2	am-3914_lhn	#10-32 NUT, LEFT HAND THREAD
3	am-3914_body	LEFT HAND TO RIGHT HAND THREADED BODY
4	am-3914_rhn	#10-32 NUT, RIGHT HAND THREAD
5	am-3914_35_rhc	#35 CHAIN ATTACHMENT CLEVIS, RIGHT HAND THREAD

UNLESS OTHERWISE SPECIFIED:		COMMENTS:				
DIMENSIONS ARE IN INCHES		DUAL DIMENSIONS ARE IN MILLIMETERS.		TITLE:		
TOLERANCES:		BREAK ALL SHARP EDGES.		#35 CHAIN		
FRACTIONAL	$\pm 1/16$			INLINE TENSIONER		
ANGULAR: MACH	$\pm 1^\circ$			SIZE	DWG. NO.	REV
ANGULAR: BEND	$\pm 5^\circ$			B	am-3914_35	1
ONE PLACE DECIMAL	± 0.1			SCALE: 1:1		
TWO PLACE DECIMAL	± 0.01			SHEET 1 OF 6		
THREE PLACE DECIMAL	± 0.005					
FOUR PLACE DECIMAL	± 0.0005					
MATERIAL		CHECKED	NAME	DATE		
FINISH		ENG APPR.	KK	6/20/18		
DO NOT SCALE DRAWING		MFG APPR.				
		Q.A.				

4

3

2

1

REVISIONS			
REV.	DESCRIPTION	DATE	DRAWN
1	ORIGINAL PRINT	6/15/2018	N. LAWRENCE

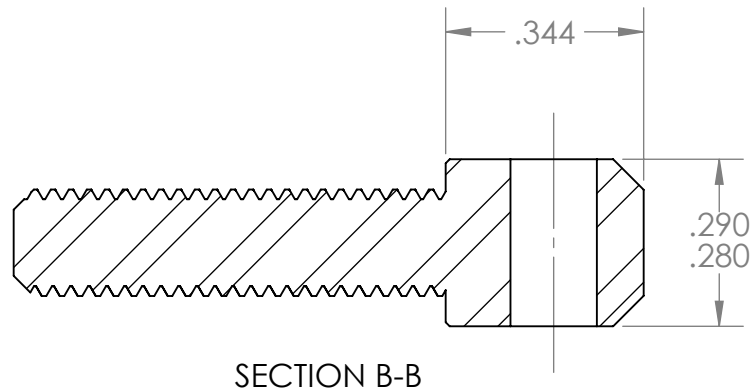
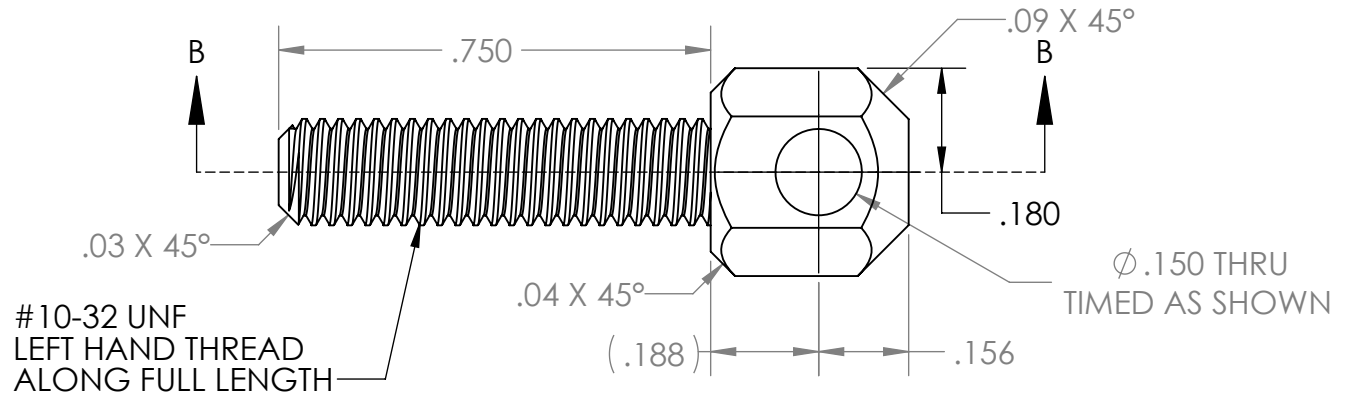
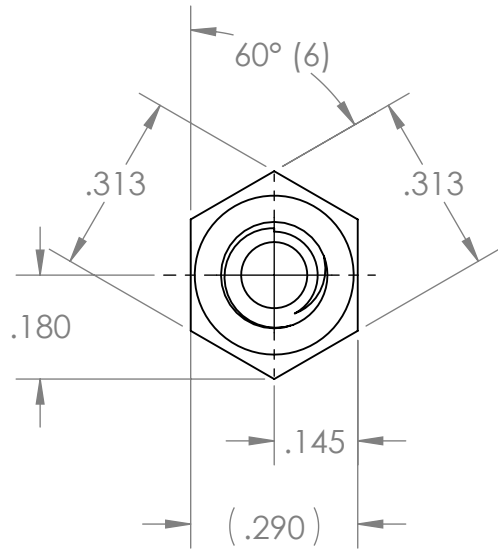

*** SEE CAD FOR ADDITIONAL TOOLPATH INFO***

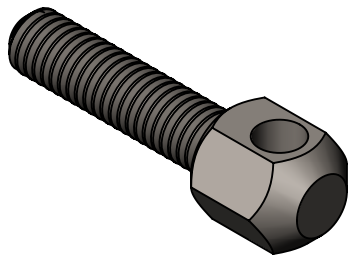

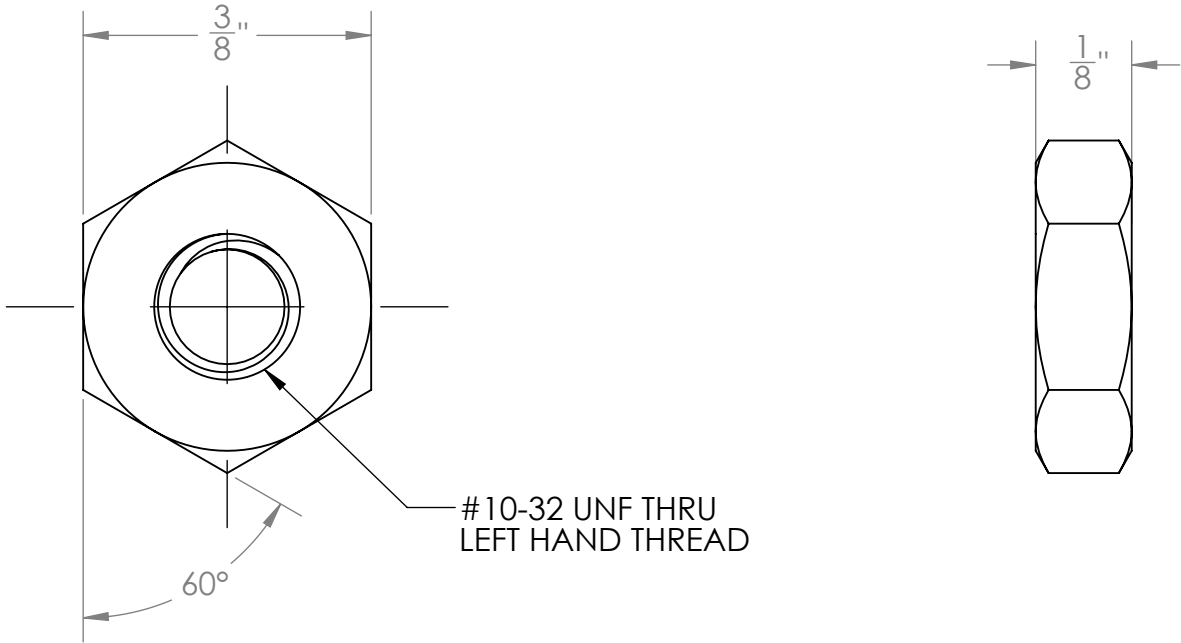

UNLESS OTHERWISE SPECIFIED:		COMMENTS:				
DIMENSIONS ARE IN INCHES		DUAL DIMENSIONS ARE IN MILLIMETERS.				
TOLERANCES: FRACTIONAL ±1/16 ANGULAR: MACH ±1° ANGULAR: BEND ±5° ONE PLACE DECIMAL ±0.1 TWO PLACE DECIMAL ±0.01 THREE PLACE DECIMAL ±0.0005 FOUR PLACE DECIMAL ±0.00005		BREAK ALL SHARP EDGES		TITLE: 35 CHAIN ATTACHMENT CLEVIS LEFT HAND THREAD		
MATERIAL 1045 CRS		NAME	DATE	SIZE	DWG. NO.	REV
FINISH ZINC PLATED		CHECKED	6/20/18	A	am-3914_35_lhc	1
DO NOT SCALE DRAWING		ENG APPR.		SCALE: 3:1		WEIGHT:
		MFG APPR.				SHEET 2 OF 6
		Q.A.				

REVISIONS			
REV.	DESCRIPTION	DATE	DRAWN
1	ORIGINAL PRINT	6/18/2018	N. LAWRENCE

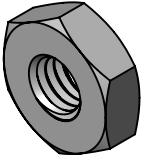

*** SEE CAD FOR ADDITIONAL TOOLPATH INFO***



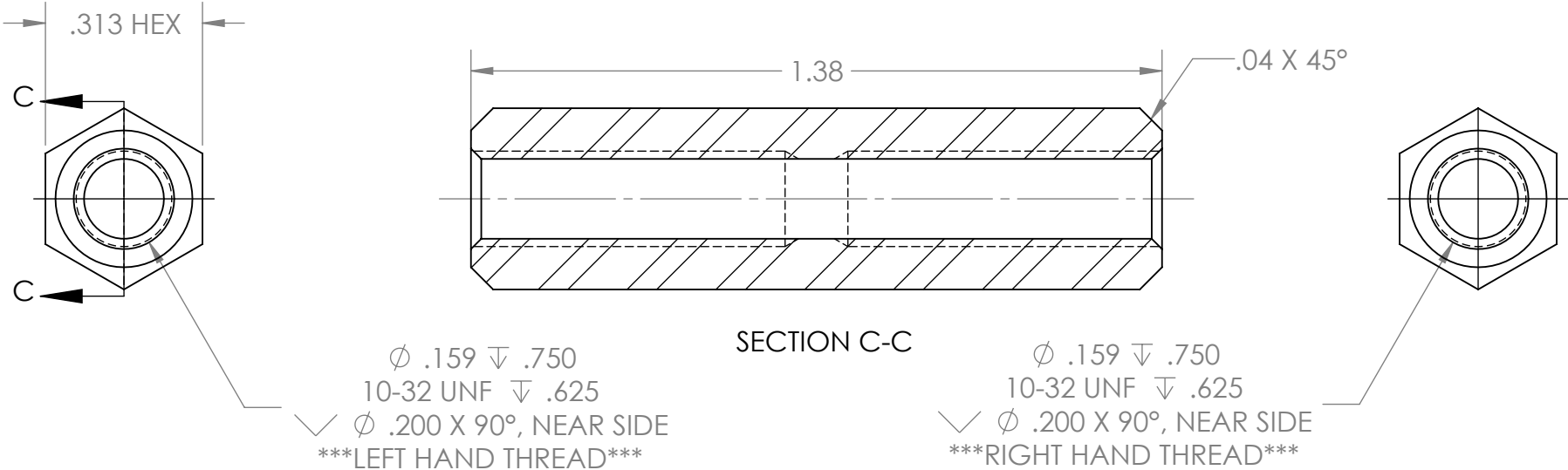

UNLESS OTHERWISE SPECIFIED:		COMMENTS:				
DIMENSIONS ARE IN INCHES		DUAL DIMENSIONS ARE IN MILLIMETERS.				
TOLERANCES: FRACTIONAL ±1/16 ANGULAR: MACH ±1° ANGULAR: BEND ±5° ONE PLACE DECIMAL ±0.1 TWO PLACE DECIMAL ±0.01 THREE PLACE DECIMAL ±0.0005 FOUR PLACE DECIMAL ±0.0005		BREAK ALL SHARP EDGES		TITLE: 10-32 LEFT HAND THREAD NUT		
MATERIAL 1018 CRS		NAME	DATE	SIZE	DWG. NO.	REV
FINISH ZINC PLATED		CHECKED	KK	6/20/18	A	am-3914_lhn
DO NOT SCALE DRAWING		ENG APPR.				1
		MFG APPR.				
		Q.A.				
		SCALE: 4:1		WEIGHT:		SHEET 3 OF 6

REVISIONS			
REV.	DESCRIPTION	DATE	DRAWN
1	ORIGINAL PRINT	6/18/2018	N. LAWRENCE

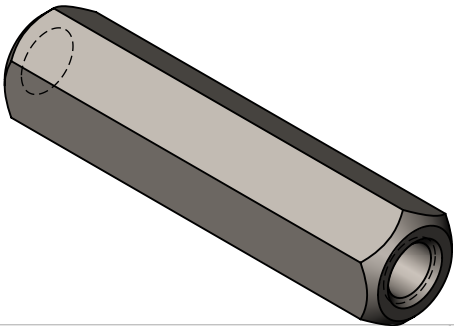

*** SEE CAD FOR ADDITIONAL TOOLPATH INFO***



UNLESS OTHERWISE SPECIFIED:		COMMENTS:				
DIMENSIONS ARE IN INCHES		DUAL DIMENSIONS ARE IN MILLIMETERS.				
TOLERANCES:		BREAK ALL SHARP EDGES		TITLE:		
FRACTIONAL	±1/16			INLINE CHAIN TENSIONER BODY		
ANGULAR: MACH	±1°			SIZE DWG. NO. REV		
ANGULAR: BEND	±5°			A am-3914_body 1		
ONE PLACE DECIMAL	±0.1			SCALE: 3:1 WEIGHT: SHEET 4 OF 6		
TWO PLACE DECIMAL	±0.01					
THREE PLACE DECIMAL	±0.005					
FOUR PLACE DECIMAL	±0.0005					
MATERIAL		CHECKED	NAME	DATE		
1045 CRS		ENG APPR.	KK	6/20/18		
FINISH		MFG APPR.				
ZINC PLATED		Q.A.				
DO NOT SCALE DRAWING						

REVISIONS			
REV.	DESCRIPTION	DATE	DRAWN
1	ORIGINAL PRINT	6/18/2018	N. LAWRENCE

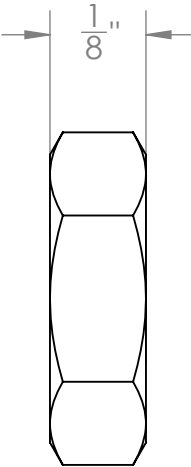
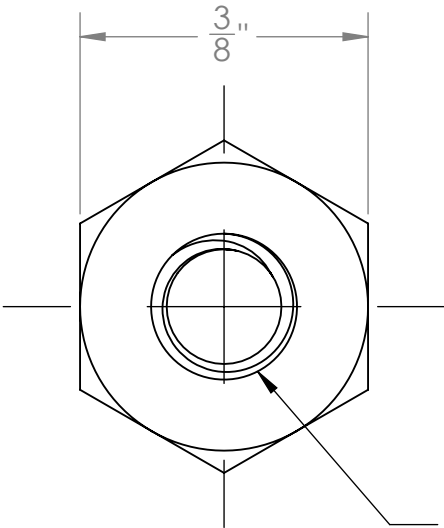

#10-32 UNF THRU
RIGHT HAND THREAD

*** SEE CAD FOR ADDITIONAL TOOLPATH INFO***

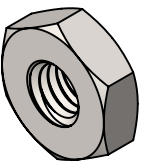

UNLESS OTHERWISE SPECIFIED:		COMMENTS:			
DIMENSIONS ARE IN INCHES		DUAL DIMENSIONS ARE IN MILLIMETERS.			
TOLERANCES: FRACTIONAL ±1/16 ANGULAR: MACH ±1° ANGULAR: BEND ±5° ONE PLACE DECIMAL ±0.1 TWO PLACE DECIMAL ±0.01 THREE PLACE DECIMAL ±0.005 FOUR PLACE DECIMAL ±0.0005		BREAK ALL SHARP EDGES		TITLE: 10-32 RIGHT HAND THREAD NUT	
MATERIAL 1018 CRS		CHECKED	NAME KK	DATE 6/20/18	SIZE A
FINISH ZINC PLATED		ENG APPR.		DWG. NO. am-3914_rhn	
DO NOT SCALE DRAWING		MFG APPR.		REV 1	
		Q.A.		SCALE: 4:1 WEIGHT: SHEET 5 OF 6	

REVISIONS			
REV.	DESCRIPTION	DATE	DRAWN
1	ORIGINAL PRINT	6/18/2018	N. LAWRENCE

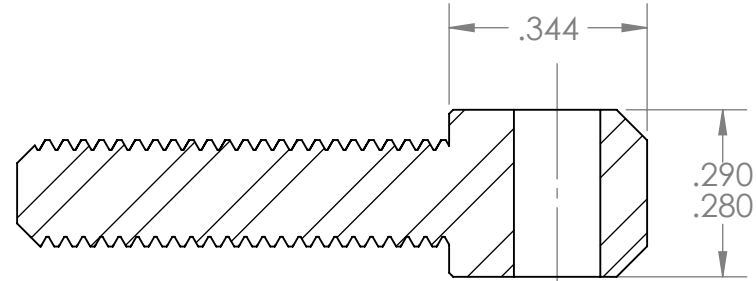
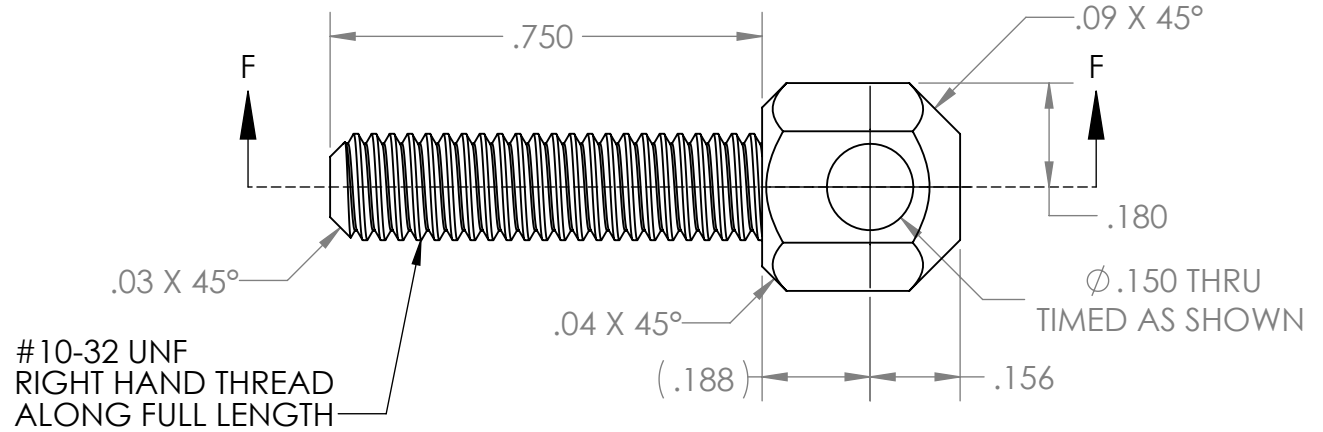
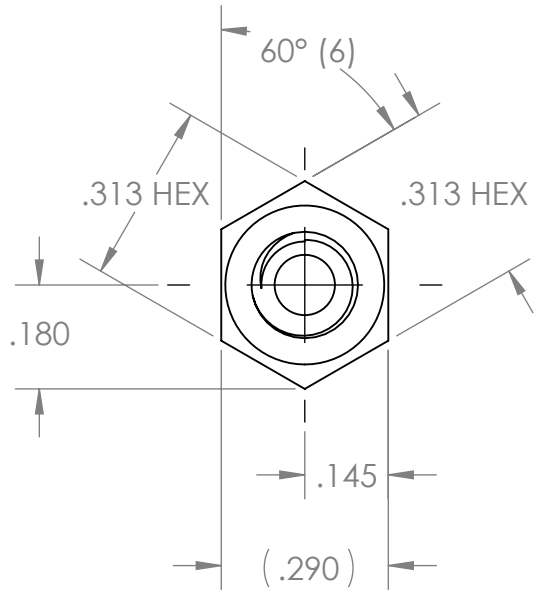

SECTION F-F

*** SEE CAD FOR ADDITIONAL TOOLPATH INFO***

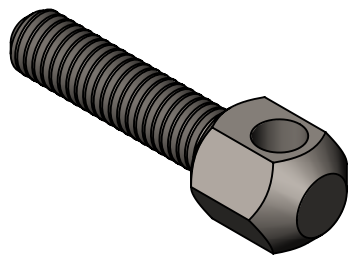

UNLESS OTHERWISE SPECIFIED:		COMMENTS:				
DIMENSIONS ARE IN INCHES		DUAL DIMENSIONS ARE IN MILLIMETERS.				
TOLERANCES: FRACTIONAL ±1/16 ANGULAR: MACH ±1° ANGULAR: BEND ±5° ONE PLACE DECIMAL ±0.1 TWO PLACE DECIMAL ±0.01 THREE PLACE DECIMAL ±0.005 FOUR PLACE DECIMAL ±0.0005		BREAK ALL SHARP EDGES		35 CHAIN ATTACHMENT CLEVIS RIGHT HAND THREAD		
MATERIAL 1045 CRS		NAME	DATE	SIZE	DWG. NO.	REV
FINISH ZINC PLATED		CHECKED	6/20/18	A	am-3914_35_rhc	1
DO NOT SCALE DRAWING		ENG APPR.		SCALE: 3:1		WEIGHT:
		MFG APPR.		SHEET 6 OF 6		
		Q.A.				