

REVISION HISTORY			
REV.	DESCRIPTION	DATE	DRAWN BY
1	ORIGINAL PRINT	1/31/2025	N. MASSOUDA
2	REVISED GEOMETRY	2/17/2025	N. MASSOUDA
3	CORRECTED HOLE SIZE	2/18/2025	N. MASSOUDA

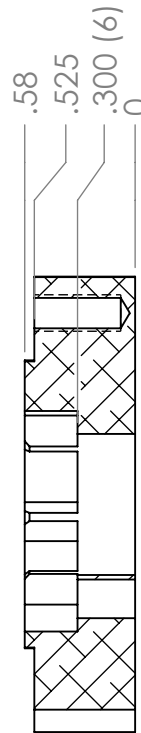

SECTION A-A

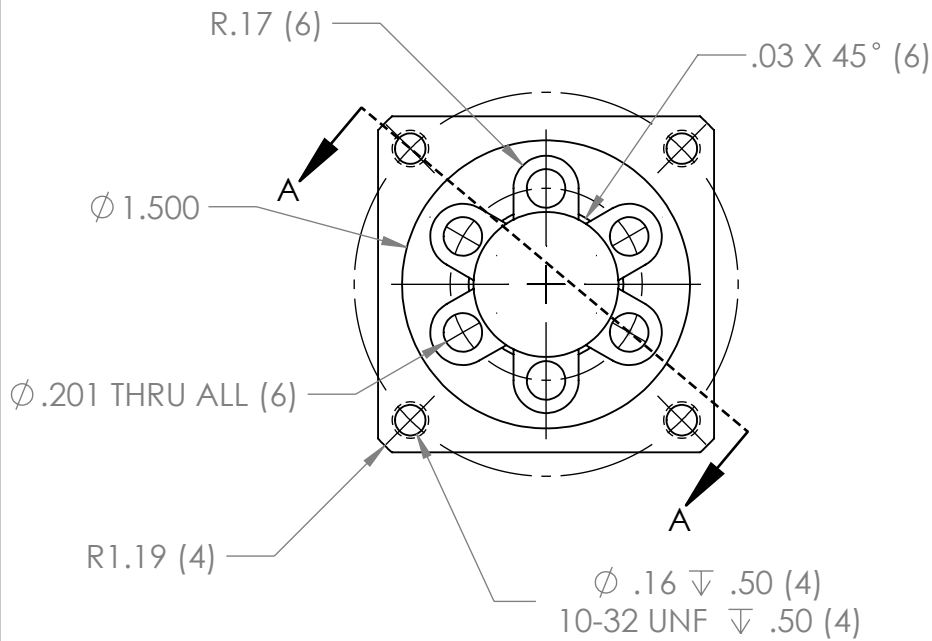
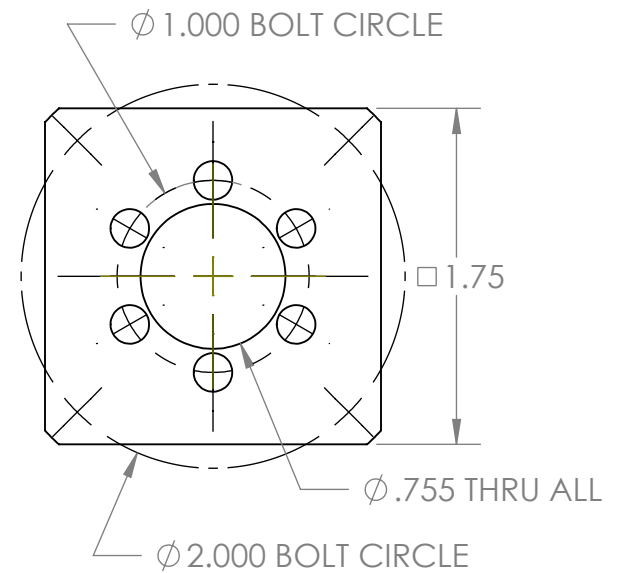

*** SEE CAD FOR ADDITIONAL TOOLPATH INFO***

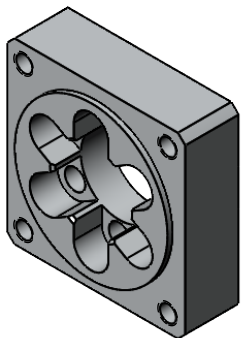

UNLESS OTHERWISE SPECIFIED:		COMMENTS:				
DIMENSIONS ARE IN INCHES		DUAL DIMENSIONS ARE IN MILLIMETERS.				
TOLERANCES:		BREAK ALL SHARP EDGES		TITLE:		
FRACTIONAL	±1/16			MINION SPORT		
ANGULAR: MACH	±1°			MOTOR BLOCK		
ANGULAR: BEND	±5°			SIZE		
ONE PLACE DECIMAL	±0.1			DWG. NO.		
TWO PLACE DECIMAL	±0.01			A am-5615		
THREE PLACE DECIMAL	±0.005			REV		
FOUR PLACE DECIMAL	±0.0005			2		
MATERIAL	6061-T6 AL	NAME	DATE	SCALE: 1:1		
FINISH	DEBURRED	CHECKED	PY	WEIGHT:		
		ENG APPR.		SHEET 1 OF 1		
		MFG APPR.				
DO NOT SCALE DRAWING		Q.A.				